

UNICEF
Innocenti Research Centre

CLIMATE CHANGE AND CHILDREN A HUMAN SECURITY CHALLENGE



unite for
children

unicef 

CLIMATE CHANGE AND CHILDREN: A human security challenge

Policy Review Paper

UNICEF Innocenti Research Centre
in cooperation with
UNICEF Programme Division

The UNICEF Innocenti Research Centre

The UNICEF Innocenti Research Centre in Florence, Italy, was established in 1988 to strengthen the research capability of the United Nations Children's Fund (UNICEF) and to support its advocacy for children worldwide. The Centre (formally known as the International Child Development Centre) helps to identify and research current and future areas of UNICEF's work. Its prime objectives are to improve international understanding of issues relating to children's rights and to help facilitate the full implementation of the Convention on the Rights of the Child in both industrialized and developing countries.

The Centre collaborates with its host institution in Florence, the Istituto degli Innocenti, in selected areas of work. Core funding for the Centre is provided by the Government of Italy, while financial support for specific projects is also provided by other governments, international institutions and private sources, including UNICEF National Committees.

The statements in this publication are the views of the authors and do not necessarily reflect the policies or the views of UNICEF. The designations employed and the presentation of the material do not imply on the part of UNICEF the expression of any opinion whatsoever concerning the legal status of any country or territory, or of its authorities or the delimitations of its frontiers.

Extracts from this publication may be freely reproduced, provided that due acknowledgement is given to the source and to UNICEF.

To download this document and any corrigenda issued subsequent to printing, or to access the most up-to-date publications, please go to the publications pages on our website, at <www.unicef-irc.org/publications/>.

©The United Nations Children's Fund (UNICEF)
November 2008

Correspondence should be addressed to:

UNICEF Innocenti Research Centre
Piazza SS. Annunziata, 12
50122 Florence, Italy
Tel: (+39) 055 20 330
Fax: (+39) 055 2033 220
www.unicef-irc.org

ISBN: 978-88-89129-83-8

Front cover photo: © UNICEF/HQ02-0258/Ami Vitale

In Malawi, a woman, carrying a baby on her back and holding the hand of a small child, and two older girls carry sacks of maize home from a small farm in the village of Chipumi, where they had worked in exchange for food. Because of droughts and flooding in recent years, many Malawians were unable to buy seeds to grow their own food crops. Harsh climatic conditions, including droughts and flooding, are among the factors responsible for the food crisis that has affected countries in eastern and southern Africa. Experts project that climate change will further impact crop production, reducing food availability in many parts of the world, with associated consequences for child health and nutrition.

ACKNOWLEDGEMENTS

This policy review was developed for the Foreign Ministry of the Government of Greece as chair of the Human Security Network, as a contribution to an initiative on the human security implications of climate change coordinated by the Hellenic Foundation for European and Foreign Policy (ELIAMEP). A summary version was presented at the International Conference on Human Security and Climate Change and the Ministerial Meeting of the Human Security Network, held in Athens, 29-30 May 2008.

Within UNICEF, this project was carried out as a joint undertaking by the Innocenti Research Centre (IRC) and Programme Division, in cooperation with other headquarters and field offices. The principal authors were Donna L. Goodman, Programme Adviser, Climate Change and Environment, UNICEF Education Section (DonnaLGoodman@aol.com), and Selim Iltus, Co-Director, Children's Environments Research Group (CERG), Graduate Center of the City University of New York (siltus@gc.cuny.edu). David Parker, Deputy Director of UNICEF IRC, coordinated its preparation, under the overall guidance of Marta Santos Pais, Director, UNICEF IRC, and Vanessa Tobin, Deputy Director, Programme Division. Yoko Akachi, Lee Cando, Michele Ferez and David Noble provided key inputs.

Appreciation is extended to the following external peer reviewers and advisers: Catherine Cameron, Agulhas Applied Knowledge; Jenny Pronczuk-Garbino and Diarmid Campbell-Lendrum, World Health Organization (WHO); Hossein Faddei, United Nations Environment Programme (UNEP); Thanos Dokos, and Stefanos Xenarios, ELIAMEP; Roger Hart, CERG; Sheridan Bartlett, International Institute for Environment and Development (IIED) and CERG; David Satterthwaite, IIED; Maaïke Jansen, UNEP; and Cecilia Ugaz, Human Development Report Office, United Nations Development Programme (UNDP).

Additional valuable comments were provided by UNICEF reviewers: Clarissa Brocklehurst, Sally Burnheim, Eva Jespersen, Changu Mannathoko, Richard Morgan, Daniel Seymour, Henk van Norden, Tessa Wardlaw and Cream Wright.

This document was copy-edited by Pamela Knight. The publication production process was coordinated by the IRC Communication and Partnership Unit. Claire Akehrst and Sandra Fanfani provided administrative assistance. All are thanked for their support.

ABBREVIATIONS

ADB	Asian Development Bank	MDGs	Millennium Development Goals
AfDB	African Development Bank	NAPA	National Adaptation Programme of Action
CCC	Core Commitments for Children in Emergencies (UNICEF)	NGO	non-governmental organization
CC:iNet	Climate Change Information Network (UNFCCC)	OECD	Organisation for Economic Co-operation and Development
CERG	Children’s Environment Research Group	OHCHR	Office of the High Commissioner for Human Rights (United Nations)
CIPRB	Centre for Injury Prevention and Research, Bangladesh	SIDS	Small Island Developing States
COP	Conference of the Parties (UNFCCC)	TASC	The Alliance for Safe Children
DFID	Department for International Development (United Kingdom)	TERI	The Energy and Resources Institute
ECOSOC	United Nations Economic and Social Council	UN	United Nations
ELIAMEP	Hellenic Foundation for European and Foreign Policy	UNCCD	United Nations Convention to Combat Desertification
ENDA	Environmental Development Action in the Third World	UNCED	United Nations Conference on Environment and Development (‘The Earth Summit’, 1992)
FAO	Food and Agriculture Organization of the United Nations	UN DESD	United Nations Decade of Education for Sustainable Development (2005–2014)
IFRC	International Federation of Red Cross and Red Crescent Societies	UNDP	United Nations Development Programme
IIED	International Institute for Environment and Development	UNEP	United Nations Environment Programme
ILO	International Labour Organization	UNFCCC	United Nations Framework Convention on Climate Change
IPCC	Intergovernmental Panel on Climate Change	UNICEF	United Nations Children’s Fund
IRC	Innocenti Research Centre (UNICEF)	UNV	United Nations Volunteers
ISDR	International Strategy for Disaster Reduction	WFFC	‘A World Fit for Children’
		WHO	World Health Organization
		YWCA	Young Women’s Christian Association

PREFACE

A humane world where people can live in security and dignity, free from poverty and despair, is still a dream for many but should be enjoyed by all. In such a world, every individual would be guaranteed freedom from fear and freedom from want, with an equal opportunity to develop fully their human potential.

Building human security is essential to achieving this goal. In essence, human security means freedom from pervasive threats to people's rights, their safety or even their lives. Human security has become both a new measure of global security and a new agenda for global action.

Safety is the hallmark of freedom from fear, while well-being is the target of freedom from want. Human security and human development are thus two sides of the same coin, mutually reinforcing and leading to a conducive environment for each other.

– A Perspective on Human Security: Chairman's Summary, 1st Ministerial Meeting of the Human Security Network, Lysøen, Norway, 20 May 1999

This paper was developed in the context of a major initiative by the Government of Greece, as Chair of the Human Security Network (2007–2008), and the Hellenic Foundation for European and Foreign Policy (ELIAMEP), to analyse and address climate change through a human security lens. The Human Security Network, operative since 1999, is composed of a group of like-minded countries from all regions of the world that maintains dialogue on modern hazards that

reach beyond borders, and identifies concrete areas for collective action. The Network places special emphasis on the myriad risks facing vulnerable population groups, including women, children and people migrating due to climate change, as they face a deteriorating natural resource base and increased extreme weather events.

As awareness of the urgency to address climate change continues to grow, governments and other stakeholders, including the United Nations System, are mobilizing to support the establishment and implementation of a new comprehensive post-2012 climate regime under the aegis of the United Nations Framework Convention on Climate Change (UNFCCC). States Parties and their partners are urged to ensure that the unique vulnerabilities and capacities of children are recognized and adequately reflected in impact assessments and policy and programmatic responses, from the local to the global level.

The study reviews the implications of climate change for children and future generations, drawing on relevant experiences in different sectors and countries of promoting child rights and well-being. It traces in considerable detail the pathways through which shifts in temperature and precipitation patterns create serious additional barriers to the achievement of the child survival, development and protection goals embraced by the international community. The role of children as vital participants and agents of change emerges as a key theme.

This paper is offered as a contribution to the ongoing reflection and discussion, within and between countries, on strategies and action to respond to climate change.

CONTENTS

Acknowledgements	iii
Abbreviations	iv
Preface	v
Executive Summary	ix
1. Climate Change, Human Security and the World's Children.....	1
1.1 Climate change and human security	2
<i>Human security risks from climate change</i>	<i>2</i>
<i>Highlights from the Fourth Assessment Report of the IPCC</i>	<i>2</i>
1.2 Climate change in developing countries.....	3
<i>Climate change and the Millennium Development Goals.....</i>	<i>4</i>
1.3 Why children?.....	4
<i>Children as researchers and as agents of change.....</i>	<i>4</i>
1.4 Complexity and integration	5
<i>Poverty, access to energy and sustainable development.....</i>	<i>5</i>
<i>The rural/urban divide</i>	<i>5</i>
<i>Age and gender.....</i>	<i>6</i>
<i>International and intergenerational justice.....</i>	<i>6</i>
1.5 The road ahead	7
2. Impacts of Climate Change on Children	9
2.1 Existing vulnerabilities and environmental health risks.....	9
2.2 Key climate changes and their impacts.....	9
<i>Rising sea levels and shrinking glaciers</i>	<i>9</i>
<i>Heavy precipitation, flooding and water security.....</i>	<i>11</i>
<i>Rising temperatures, droughts and desertification</i>	<i>11</i>
<i>Extreme weather events</i>	<i>11</i>
<i>Deforestation</i>	<i>11</i>
<i>Biodiversity</i>	<i>11</i>
2.3 Implications for child health and well-being.....	12
<i>Food security and undernutrition</i>	<i>12</i>
<i>Water security, diarrhoea and other waterborne diseases.....</i>	<i>12</i>
<i>Malaria and other vector-borne diseases.....</i>	<i>12</i>
<i>Death and illnesses from use of biomass fuels indoors.....</i>	<i>12</i>
<i>Impacts from the breakdown of economic and social structures.....</i>	<i>12</i>
3. The Bases for Action: Rights, institutions and guiding principles	15
3.1 Human rights and the environment	15
3.2 Convention on the Rights of the Child	16
3.3 Climate change and the Millennium Development Goals.....	16
3.4 Agenda 21 and the Rio Conventions	18
3.5 Aarhus Convention	18

<i>Article 6 of the United Nations Framework Convention on Climate Change</i>	18
3.6 Partnerships with faith-based organizations	18
3.7 Partnerships with youth organizations.....	18
4. Adaptation and Mitigation: Complementary strategies	21
4.1 Mitigation and adaptation	21
<i>Eight key adaptation interventions</i>	22
<i>Addressing the needs of children in local adaptation strategies</i>	23
4.2 Participatory community development.....	23
<i>Strengthening basic public health infrastructure</i>	23
4.3 Environmental education	23
4.4 Child and youth participation.....	26
4.5 The Nairobi Work Programme	27
4.6 Frameworks for action.....	27
<i>National Adaptation Programmes of Action</i>	27
<i>Hyogo Framework for Action 2005-2015</i>	28
<i>Roll Back Malaria</i>	28
<i>Subnational and municipal frameworks</i>	28
<i>Local adaptation strategies and local action</i>	28
5. Implications and Conclusions for Policy and Practice	31
Annexes	
A - Case Study: Southern Sudan.....	35
B - Case Study: Morocco.....	39
C - References to the environment in the Convention on the Rights of the Child	43
D - An example of local adaptation in Kenya	44
Bibliography.....	45

EXECUTIVE SUMMARY

The evidence presented in this review confirms the centrality of children and their unique vulnerabilities to global, national and subnational policies and frameworks on climate change and human security. It also identifies a gap in existing agreements, protocols and policies that have not sufficiently recognized or addressed children's issues in the past.

The Convention on the Rights of the Child, adopted by the United Nations General Assembly in 1989 and ratified to date by 193 countries, together with 'A World Fit for Children' (WFFC), protect and preserve the right of every child to a safe, healthy environment in which to develop and grow. The WFFC Declaration, which was a consensus outcome from the UN General Assembly Special Session on Children held in 2002, articulates clearly the commitment of States "to give every assistance to protect children and minimize the impact of natural disasters and environmental degradation on them." Together with the Millennium Development Goals (MDGs), these international commitments are of the greatest relevance for addressing the myriad threats that climate change raises for the world's children.

Protecting the environment and providing for the health, education and development of children are mutually inclusive goals. Almost any action taken to enhance environmental quality also helps meet the basic needs of children. It is therefore important not to separate climate change from other priorities, but rather to integrate comprehensive actions to include climate risk in development planning, programmes and projects.

The strong institutional basis for inclusion of children's issues in the international climate regime has yet to align with an emerging mechanism for championing children's issues in the sector. For example, National Adaptation Programmes of Action (NAPAs) and other adaptation plans rarely, if ever, reference the unique vulnerabilities of children or address their needs. Similarly, they fail to draw on the practical knowledge, insights and

capacity for meaningful change that children can and do offer, most notably at subnational and community levels.

This paper seeks to substantiate the need for frameworks and protocols that will recognize, protect and empower children and young people in light of the effects of climate change. Thus, the major messages of this paper are that:

- A human rights-based approach necessitates inclusion of children's issues in all international and national efforts, most notably the climate change regime following the UN Climate Change Conference in Bali, NAPAs and poverty reduction strategies.
- There is an increasingly convincing body of evidence that many of the main killers of children (malaria, diarrhoea and undernutrition) are highly sensitive to climatic conditions.
- The complexity of the challenges posed by the changing global environment calls for an integrated approach. The challenges of providing access to clean household energy, water, sanitation and education, are compounded by the increasing and chronic prevalence and severity of natural disasters, and are often simultaneous (*also see Figure 4.1, page 24*).
- Intersectoral coordination and collaboration between line ministries (including Education, Health, Environment, Youth and Finance) are essential for paying special attention to the needs and vulnerabilities of children of different ages.
- Scaling up efforts to meet the MDGs will reduce risk caused by many of the social and economic factors that are shown to exacerbate and increase the impacts of climate change, thereby increasing the resilience of the most vulnerable children.
- Gender-sensitive participatory approaches to community development, including water and energy stewardship, environmental education, food security and disaster risk-reduction activities,

will create economic opportunity, reduce vulnerability and empower the most marginalized citizens to take part in creating a sustainable society.

- Empowered children are dynamic and ultimately powerful protagonists for protecting and improving the environment. Today's children and future generations bear the brunt of the climate change impacts, but they are also great forces for change. As such, they have a right to be involved not only locally, but also in the current international negotiation process.
- Partnerships are key. The wide-reaching complexity of climate change is too large for any

one organization to tackle alone. A coherent, cooperative partnership between governments, civil society, UN organizations, donors, the private sector and every individual (inclusive of and taking into account generations and genders) is needed to reduce and mitigate risk at all levels.

It is clear from all perspectives that children are central to the climate change and human security agenda. They are among the populations that are most vulnerable to climate change, and may be the greatest victims of its impacts. At the same time, they are powerful protagonists for change and can contribute significantly to the collective effort to mitigate climate change and its effects.

1

CLIMATE CHANGE, HUMAN SECURITY AND THE WORLD'S CHILDREN

This is the moral challenge of our generation. Not only are the eyes of the world upon us. More importantly, succeeding generations depend on us. We cannot rob our children of their future.

– United Nations Secretary-General, Ban Ki-moon
Address to the High-Level Segment of the UNFCCC
Conference of the Parties (COP 13) negotiations in Bali,
Indonesia, 12 December 2007

Over the years since the adoption and subsequent ratification of the Convention on the Rights of the Child by 193 countries, significant efforts and great strides have been made to ensure that children (defined as people under the age of 18), regardless of gender, origin, religion or disability status, need special care and protection because they are often the most vulnerable. Accordingly, today, more than ever before, young people are recognized as rights-bearing citizens and are playing an active role in asserting their rights.

In 2002, the global community built on its commitments to children, when the United Nations General Assembly held a Special Session on Children, in which 189 Member States reaffirmed their earlier pledge and further agreed on goals and targets towards 'a world fit for children.' The WFFC Declaration very clearly articulates the commitment of States "to give every assistance to protect children and minimize the impact of natural disasters and environmental degradation on them,"¹ as well as to "listen to children and ensure their participation."²

Together, the Convention on the Rights of the Child and WFFC Declaration oblige signatory nations to protect the right of every child to a safe, healthy environment in which to develop and grow and to recognize them as resourceful citizens, capable of helping to build a better future for all, in accordance with their age and maturity.

Accordingly, it is recognized that achievement of the Millennium Development Goals (MDGs) would reduce risk to many of the world's most vulnerable

children and build resilience within their communities. The UNDP *Human Development Report 2007/2008* affirms, however, that climate change is already slowing progress on the MDGs. If left unattended, according to the report, "it will lead to human development reversals throughout the 21st century."

Protecting the environment and providing for the health, education and development of children are mutually inclusive goals. Almost any action taken to enhance environmental quality also helps meet the basic needs of children.³ It is therefore important not to separate climate change from other priorities, but rather to take an integrated approach to include climate risk in development planning, programmes and projects.⁴

Intergenerational justice and development considerations also factor into the equation. In fact, in December 2007, at the opening of high-level intergovernmental negotiations in Bali, Indonesia, UN Secretary-General Ban Ki-moon told ministers and Heads of State: "Climate change affects us all, but it does not affect us all equally. Those who are least able to cope are being hit hardest. Those who have done the least to cause the problem bear the gravest consequences."

The political will to address the social and economic effects of climate change has gained an undeniable relevance in the international agenda in recent years. Yet, children's issues have not been well recognized or addressed within existing international and national climate regimes and environmental law. To this end, WFFC recognizes that "the implementation of the present Declaration and the Plan of Action requires not only renewed political will but also the mobilization and allocation of additional resources at both the national and international levels, taking into account the urgency and gravity of the special needs of children."⁵

Today's children and future generations bear the greatest burden of climate change impacts. But while children are among the greatest victims of climate change, they are *not only* victims. In many

well-documented cases it is seen that empowered and well-educated children can influence the adults in their lives, bringing about meaningful and sustainable change.⁶ To this end, it is critically important to consider a participatory and skills-based approach that will educate today's children and young people to be proactive and prepared citizens, empowered to adapt and respond to rapidly changing environments. Their education should prompt young citizens to question and modify existing conditions and structures and move towards enhanced development objectives and disaster risk reduction and preparedness activities.

The aim of this paper, therefore, is to present the evidence and analysis necessary to effectively influence advocacy, policy and programme development. The ultimate goal is to provide the opportunity for children and young people to develop to their full potential, both by ensuring that their communities and homes are more capable of withstanding the impacts of climate change and by providing support and encouragement for their participation and contributions to the collective global response.

Consideration for the rights and capacities of children within and across all levels of emerging climate policy is, therefore, an imperative. Children's issues should be incorporated into all international and national efforts – most notably, they should be addressed within the post-Bali climate regime, within NAPAs and in international and national poverty reduction strategies. International support for adaptation, preparedness and risk reduction initiatives at subnational levels should involve children and young people as stakeholders and be coordinated across all sectors.

Lastly, both climate change mitigation and adaptation are necessary to protect human security against climate change risks,⁷ as detailed in Section Four of this paper. **Mitigation** means taking action to reduce greenhouse gas emissions to avoid further climate change than will already occur due to historic and current emissions. **Adaptation** refers to changes in natural and human systems to reduce risks to the lives and livelihoods of people. Adaptation actions can reduce many unavoidable impacts in the near term, although they cannot reduce them to zero. Failure to mitigate will eventually lead to failure of adaptation because the magnitude of the impacts is predicted to become too large to manage even with considerable investment. Adaptation and mitigation are not alternative strategies but complementary ones that need to be pursued together.

1.1 Climate change and human security

Human security risks from climate change

Human security is a people-centred notion of security that seeks to integrate the various determinants of well-being. These include economic,

food, health, environmental, personal, community and political security. Risks to human security can be classified in terms of acute risks from sudden disruptions – such as natural disasters – and chronic threats, such as disease, hunger and conflict. Human security is complementary to the more conventional formulation of national security. Neither can be achieved without the other. In fact, human security is a unifying concept that bridges notions of security at all levels, from the individual and/or local (i.e. human security) to the national (i.e. state security) and global (i.e. international security).

Human security offers a valuable lens through which to examine the impacts of climate change on children, and to integrate the climate change and development agendas. Both the sudden-onset disasters and gradual systemic changes that are anticipated in a warmer climate will impact on children in every one of these areas. UN Secretary-General Ban Ki-moon recently cited four key risks to human security from climate change: political instability, economic weakness, food insecurity and large-scale migration. Risks in these areas will result in a wide range of adverse outcomes for children, including increased child mortality, undernutrition and loss of education. Thus human security is a goal common to the international climate and development communities.

Many of the world's poorest countries and communities will be increasingly challenged by a double-edged threat – that of climate change and violent conflict. Current trends indicate a heightened risk that climate change will exacerbate violent conflict in volatile regions. Conversely, conflict is known to render communities poorer, less resilient and less able to cope with the consequences of climate change. It is estimated that there are 46 countries – home to 2.7 billion people – in which the effects of climate change interacting with economic, social and political problems will compound an already high risk of violent conflict. There is a second group of 56 countries – home to 1.2 billion people – in which the outbreak of violence represents a distinct possibility in the longer term.⁸

Children are often the primary victims of armed conflict. They are both its targets and, increasingly, its instruments. Their suffering bears many faces, born in the midst of armed conflict and its aftermath; children may be killed or maimed, orphaned, abducted, deprived of education and health care, and left with deep emotional scars and trauma.⁹ As noted above, climate change is likely to increase the risk of violent conflict in volatile regions, where the majority of the world's children live.

Highlights from the Fourth Assessment Report of the Intergovernmental Panel on Climate Change

In its Fourth Assessment Report (AR4), issued in 2007, the Intergovernmental Panel on Climate Change (IPCC) presented its most confident and convincing assessment yet on the science of climate change and its implications for all human beings. It reaffirmed that anthropogenic greenhouse gas

emissions are the primary cause of recent global warming, and emphasized the dangers to humanity of rising mean global temperatures. It concluded that immediate and sustained action is required to stop climate change if irreversible and potentially catastrophic damages are to be avoided.¹⁰

Some of the most significant changes predicted are summarized in Table 1.1 below, together with the likelihood of their occurrence.

These changes are expected to increase the risks of both large-scale, sudden-onset disasters and more gradual and chronic systemic changes.

- **Sudden-onset disasters** can shatter the world of a child in a matter of moments, destroying familiar surroundings and resulting in injuries, undernutrition or disease in the aftermath. Children may become orphaned or separated from their families, and may be preyed upon by opportunistic adults.¹¹

- **Gradual systemic change**, including incremental ecosystem deterioration, will lead to long-term drought conditions in many regions, adding stress to and exacerbating the existing untenable conditions facing the most marginalized children.

Melting of glaciers that supply freshwater to large population centres, sea level rise leading to saline intrusion into sources of freshwater for agriculture and drinking, changes in the spectrum of vector-borne diseases, and increasing air pollution from the continued burning of fossil fuels also threaten children’s health, quality of life, access to education and overall development.

These climatic events will have direct implications for the physical environment that children live in. Not all areas will be affected equally. There will be differences across geographic regions and between urban and rural settlements.

1.2 Climate change in developing countries

The evidence we have today suggests that developing countries – which are mostly located in warmer regions and whose major source of income is agriculture – will be worst hit by changes in rainfall patterns, greater weather extremes and increasing incidence of droughts and floods.¹²

Changes in precipitation patterns are likely to affect the quality and quantity of water supplies, thus compounding the existing challenges related to poor water, sanitation and food security. Weather-related physical hazards, such as hurricanes and flooding, are likely to intensify, resulting in more deaths, injuries and trauma, dehydration and undernutrition.

Developing countries are most vulnerable to climate variability and change, due to the multiple stresses they face and their low adaptive capacity. In many cases, they are already struggling with many social and environmental issues. For example, threats to the environment have clearly increased in recent years. We appear to be reaching a number of ‘tipping points’ beyond which change is irreversible.¹³ Climate change will be an additional burden with which, in many cases, people in developing countries will be unable to cope. As a consequence, they are at risk of the greatest impacts. For example:¹⁴

- In **Africa** by 2020, between 75 million and 250 million people are projected to be exposed to increased water stress. Agricultural production in many countries, including access to food, is projected to be severely compromised by climate variability and change.

- In **Asia** by 2050, decreasing freshwater availability in most areas could put more than a billion people at risk. Increased deaths and illness are expected from cholera and from diarrhoeal diseases, associated with increased flooding and drought that result from higher sea temperatures.

- In **Small Island Developing States**, rising sea levels and increased storm surges will threaten the homes and livelihoods of communities, and will force displacement and permanent migration.

In the most vulnerable regions, the survival of many children and their families is contingent on a precarious balance. We often fail to recognize the value of something that has been traditionally consistent and supportive over time, such as fertile land and a steady climate. Yet, a changing climate is rapidly becoming a critical and destabilizing factor for many people. Even small changes in climate can make the difference between sustainable growth and development in a community, and chronic poverty, forced migration, diminished health and death.

TABLE 1.1
IPCC assumptions of climate change, 2007

Phenomena and direction of trend	Likelihood
Over most land areas, warmer and fewer cold days and nights, warmer and more frequent hot days and nights	Virtually certain
Warm spells/heat waves. Frequency increased over most land areas	Very likely
Heavy precipitation events. Frequency increases over most areas	Very likely
Area affected by drought increases	Likely
Intense tropical cyclone activity increases	Likely
Increased incidence of extreme high sea level (excludes tsunamis)	Likely

Source: Intergovernmental Panel on Climate Change, *Climate Change 2007: The physical science basis*, Fourth Assessment Report, Cambridge University Press, Cambridge/New York, 2007.

CASE STUDY

The Young Women's Christian Association of Malawi

Because of existing traditional gender roles, in many rural areas (especially in developing countries) the burden of responsibility for securing the food, water and energy for cooking, cleaning, drinking and heating lies with women and girls. Certain effects of climate change, like drought and unpredictable rainfall, can create more work for women and girls, making it even more difficult for them to secure these resources. This leaves very little time for girls to get an education, and for women to generate income and take care of their families. In fact, girls quite often have to drop out of school to help their mothers gather food, fuel and water.

This was the case in the Mondwa village of Malawi in 2003. Women and girls consistently had to miss their literacy classes at the YWCA because they spent so much time fetching clean water for cooking and washing in the village. Determined to reduce the risk of disease and the burden on the women and girls, members of the YWCA began discussing the problem with Mondwa residents. The YWCA members persisted in their efforts and gained support from the village people to pursue the construction of a water well system. Then, with a grant from the World YWCA and money raised through local fund-raising efforts, the YWCA of Malawi drilled boreholes in order to provide potable water to the community. For sustainability of the project, the YWCA began providing freshwater management training to residents. Today, the women and girls of Mondwa no longer have to wake up at 2 a.m. to queue for water, and their water source is no longer plagued by health risks, like cholera. The women have also attended YWCA literary classes in great numbers.

Source: World Alliance of YMCAs, Geneva, 2008.

Climate change and the Millennium Development Goals

Climate change has the potential to jeopardize existing efforts to meet the Millennium Development Goals (MDGs). Climate change is inextricably linked to the broader sustainable development agenda to reduce poverty, child mortality and morbidity, and to ensure universal primary education for all children. Not only are all of the MDGs critically important and relevant to the lives of children today, but their achievement is also crucial to the world we leave to future generations. The relationships between climate change and the MDGs are detailed further in Section 3.3 of this paper.

1.3 Why children?

The world's population is young, with some 2.2 billion people under the age of 18.¹⁵ Statistics show that:

- Over 1.2 billion people in the world are nine years old or younger. Of these, 625 million are under five years old.¹⁶
- Over 1.2 billion people are adolescents, aged between 10 and 19 years old.¹⁷
- About 85 per cent of the world's youth live in developing countries.¹⁸

As a group representing nearly one third of the world's population, the vulnerability and experience of children comprise a crucial and relevant component of the overall profile of human security. Even in industrialized countries with higher incomes, some people (such as the poor, young children and the elderly) are known to be particularly at risk.¹⁹

There is an increasingly convincing body of evidence that **many of the main killers of children (malaria, diarrhoea and undernutrition) are highly sensitive to climatic conditions**. These are expected to worsen as a result of climate change.²⁰

More generally, children are exposed to a barrage of environmental threats that are also expected to intensify as a result of climate change.

Compared to adults, children are **more susceptible to the adverse effects of environmental degradation**, because of their physical, cognitive and physiological immaturity. They are therefore more vulnerable to adverse environmental conditions, such as poor air quality,²¹ contaminated water and extreme heat. In poor countries, where indoor space is limited and not suitable for play, children often spend long periods of time outdoors, exposed to the sun and with no protective clothing. This makes them more susceptible to the effects of intense and harmful ultraviolet radiation. Similarly, children are psychologically more sensitive to sudden disruptions of their lives caused by forced migration and natural disasters.

Growing children are particularly vulnerable; their physical characteristics, childhood activities and natural curiosity put them at greater risk from environmental hazards. In fact, the quality of a child's environment is a key determinant of whether a child survives the first year of life and of her or his further physical and mental development.²² Older children face different risks in relation to the environment and the constraints that it imposes on their physical, mental, social and emotional development.

The circumstances and **experiences of children today set the stage for human security in the future**. Research findings increasingly point to the critical imprints that childhood health, nutrition and education leave on long-term adult mental and physical health and ability to contribute to a sustainable society.²³

Children as researchers and as agents of change

While children are among the most vulnerable to climate change, they need not be considered passive or helpless victims under all circumstances. In fact,

studies have found that “many children can be extraordinarily resilient in the face of significant challenges.”²⁴ Older children often play a valuable role in identifying environmental problems and coming up with viable solutions based on their own knowledge and experience.

Children can be important agents for social change, economic development and technological innovation and are also likely to use environmental resources in fundamentally new ways. They have an inherent curiosity about the environment and seek to understand their place in the world from an early age. The knowledge and capacities of children can be invaluable to the development of realistic and practicable adaptation plans.

In developing countries, children are often better in touch with their physical environment compared to their counterparts in industrialized countries and to adults. In most communities, they have a wide range of access: They play along riverbeds, in empty lots and in isolated areas, and have a wide knowledge of the physical environment. This kind of knowledge is invaluable and hard to find in the adult world. By raising their awareness of risk factors, strengthening capabilities and giving them opportunities to engage, children and young people can develop positive attributes and skills that will help safeguard both the environment and their own health and livelihoods.²⁵

Children and young people can be meaningfully engaged through more participatory approaches to community research and development. There are many excellent examples of children getting involved in local research that would otherwise be impossible to conduct. For example, in Tajikistan, using inexpensive testing kits, children in hundreds of schools are engaged in data collection on the quality of water in their schools and neighbourhoods. As a follow-up to the activity, a comprehensive map of water quality and associated water-related illness linked to school attendance is being developed to be used as a basis for policy decisions.²⁶

This local knowledge and innovation needs to be respected and legitimized. It is important for adults to acknowledge, disseminate and act on the information generated by children. In this regard, it is important for adult decision makers to see themselves as mentors and partners of children in this process, rather than as controlling agents.

There is a wide range of tested methodologies for involving and engaging children and young people. Focus groups, community mapping exercises, disaster preparedness plans and systematic analysis of the everyday lives of children are a few of these methods.²⁷ For children to become effective agents of change, avenues must exist for their knowledge to be translated into advocacy and action. Programmes and policies that take children’s perspectives into account from the outset can produce better results for everyone concerned.²⁸

Many of the world’s leading youth organizations are present in most countries and have the global voice to advocate for this kind of involvement, providing

tools and mechanisms for decision makers to support the actions of children and young people in their communities and for intergenerational partnership. These guidelines for working with children and young people’s organizations at national and subnational levels can and do make significant, yet subtle, impacts on local environments in support of climate change and adaptation agendas.

1.4 Complexity and integration

Poverty, access to energy and sustainable development

The unequal distribution of energy resources worldwide and the absence of cost-effective sustainable energy technologies leave large, impoverished populations without access to clean energy.²⁹ A lack of access to clean household energy in developing countries forces more than a third of humanity – 2.4 billion people – to cook and heat their homes by burning wood, dung and crop waste. These families face an impossible dilemma: Cook with solid fuels and suffer the health consequences, or go without a cooked meal.³⁰

Smoke in the home claims the lives of nearly 800,000 children each year. Newborns and infants are often carried on their mothers’ backs while they are cooking, or kept close to the warm hearth.³¹ As a result, they spend many hours breathing polluted air during their first year of life – just when their developing airways and immune systems are most vulnerable.³² In addition, lack of access to household energy interferes with a child’s access to education, especially for girls, who traditionally need to fetch firewood or other fuels for cooking and heating.

The rural/urban divide

Climate change will affect urban and rural settlements in different ways. The experiences of children in each of these settings will therefore be very different.

In urban areas, poor communities often live in the most hazardous and unhealthy environments. They contend with extreme levels of air pollution, toxic and polluted water, unsanitary conditions, water shortages, and loss of property and jobs as a result of minor and major disasters. As people crowd into cities, human impacts on urban land surfaces and drainage intensify. Even moderate storms now produce high flows in rivers because of surface run-off from hard surfaces and clogged drains. Urban flooding is becoming a much more severe and more frequent problem for the urban poor. Water flowing through a series of culverts and concrete channels cannot adjust to changes in the frequency of heavy rain as natural streams do.³³

Rural households represent a large majority of the population in sub-Saharan Africa. In Kenya, for example, 80 per cent of the population lives in rural areas.³⁴ Rural households are in many cases the

managers of local resources, and their activities are critical both to their own livelihoods and survival (for example, the need to walk long distances to collect water and wood). These households are also responsible for the local environment and often inadvertently exacerbate desertification and other climate-related impacts, e.g. by overgrazing and cutting trees for firewood.

Age and gender

There is a tendency to generalize the impacts of climate change for all children, without reference to age and gender. This practice omits or overlooks some critically important and distinguishing attributes of children of different ages and genders.

There are more extensive data and a better understanding of the impacts of climate change on young children compared to older children. For example, research shows mortality from diarrhoea and malaria is much higher for young children.³⁵ Each year, more than 75 per cent of all deaths from malaria occur in African children under the age of five who are infected with *Plasmodium falciparum*.³⁶ By contrast, there is very little epidemiological data for children over five and for adolescents. This is a major knowledge gap. As a consequence, it is more difficult to communicate the effects of climate change on older children to the adult world. This is unfortunate because better knowledge in this area would further validate efforts to actively involve adults in mitigation and adaptation activities. Efforts are needed to identify and fill this and other remaining knowledge gaps regarding climate change and children, and to create pathways of communication and action involving a wide range of partners.

Gender is a distinguishing attribute, since, in many regions, boys and girls have different lifestyles and responsibilities. Young girls, for example, often assist with domestic tasks like fetching water and cooking, whereas boys may assist with herding cattle or working in the market to supplement family income. These differences inevitably point to different types of vulnerabilities for girls and boys in the face of climate change. Social and cultural preferences can play a significant role in survival rates for boys and girls. For example in India, girls are 30 per cent more likely to die before their fifth birthday, compared to boys – a result of family preference where boys are provided with better health care compared to girls when they fall ill.³⁷

The workload of women and young girls also increases disproportionately during drought and in the aftermath of natural disaster. Women and girls, who are natural resource labourers (collecting firewood, carrying water, etc.), are compelled to work harder as their health deteriorates and working conditions worsen.³⁸ During disasters, women and children in developing countries may face higher risks compared to men. An estimated 90 per cent of victims in the 1991 cyclone disaster in Bangladesh were women and children.³⁹ The reasons for this divergence are varied. For example, in societies where women are not allowed to interact with men with whom they are not acquainted, women are less

likely to leave their homes with their children to go to shelters in the case of a flood or cyclone.⁴⁰ A study of mortality estimates in Aceh, Indonesia after the tsunami⁴¹ concludes that “there is clear evidence of differential impact by both age and gender, where children, older adults, and women were disproportionately affected.”⁴²

International and intergenerational justice

Climate change raises major issues for both international and intergenerational justice. In this context, these notions refer to the fairness or justice of the distribution of wealth, opportunities for development and human security risk across countries and across generations.

This aspect of the climate change discourse is critical. Most of the greenhouse gas emissions that have caused and will continue to contribute to climate change are from high-income countries, and are the by-product of the development process that has distanced higher-income countries from the developing world. Meanwhile, most of the human security risk will be to middle- and low-income countries, including many whose historical and ongoing contributions to climate change are negligible. Failure to mitigate sufficiently in high-income nations will create an ever-greater likelihood of adaptation failures and impacts, mostly in low- and middle-income nations.

According to Archbishop Desmond Tutu of South Africa:

*Adaptation is becoming a euphemism for social injustice on a global scale. While the citizens of the rich world are protected from harm, the poor, the vulnerable and the hungry are exposed to the harsh reality of climate change in their everyday lives. Put bluntly, the world's poor are being harmed through a problem that is not of their making. The footprint of the Malawian farmer or the Haitian slum dweller barely registers in the Earth's atmosphere.*⁴³

This point is underscored in the 2007/2008 *Human Development Report*, which emphasizes the large gap in adaptation capacity between countries of the North and of the South, and among countries of the South. Indeed, the coping mechanisms to address the impact of climate change for children in London, Los Angeles and Tokyo are quite different from equivalent impacts on the children among the 2.6 billion people living on less than US\$2 a day.

The discussion of inequity across countries is easily extended to inequities between adults and children and a more fundamental discussion of intergenerational justice, which refers to the fairness or justice of relationships between children, youth, adults and future generations. Intergenerational justice is implicit in sustainable development, and is increasingly being recognized explicitly in international agreements. For example, the Convention on Access to Information, Public Participation in Decision-Making and Access to Justice in Environmental Matters (the 'Aarhus

Convention'), which is an agreement under the UN Economic Commission for Europe, furthers the concept of intergenerational justice by acknowledging that we owe an obligation to future generations.

1.5 The road ahead

The Intergovernmental Panel on Climate Change Fourth Assessment Report confirmed that anthropogenic greenhouse gas emissions are the primary cause of recent global warming, and emphasized the dangers to humanity of rising mean global temperatures. It concluded that immediate and sustained action is required to stop climate change if irreversible and potentially catastrophic damages are to be avoided.⁴⁴

At the High-Level Event on Climate Change, convened by the United Nations Secretary-General at UN Headquarters in September 2007, world leaders unequivocally committed to tackling climate change through concerted action. Importantly, they agreed that the United Nations Framework

Convention on Climate Change (UNFCCC) was the only negotiation forum.

Since then, the UNFCCC Conference of the Parties discussions in Bali, Indonesia, at the UN Climate Change Conference in December 2007 (COP 13) culminated in the adoption of the 'Bali Road Map'. The road map is an agreement on a two-year negotiating process, to be concluded at the COP-15 negotiations in Copenhagen in 2009, which will ultimately lead to a post-2012 international agreement on climate change.

The road map has been drawn, but the rules of the road have not been laid down. The question remains: How do we ensure that the rules of the road acknowledge and encompass the peripheral landscape in order to protect the poor and most marginalized children who may otherwise be missed?

Clearly, the new post-2012 climate change regime must be devised and built on existing legal and institutional frameworks. Together, these will then provide a platform for understanding the impact of climate change on children and supporting relevant adaptation and mitigation measures.

NOTES

- 1 UN General Assembly Resolution S-27/2, 2002, A world fit for children, paragraph 7, section 10.
- 2 Ibid., paragraph 7, section 9.
- 3 UNICEF, *Climate Change and Children*, December 2007.
- 4 World Bank, *Climate Risk Management - Integrating adaptation into World Bank Group operations*, 2006.
- 5 UN General Assembly Resolution S-27/2, 2002, A world fit for children, op. cit., paragraph 8.
- 6 For example, United States National Institutes of Health, 'Rural Front Against AIDS, Mbarara, Uganda', International Conference on AIDS, July 7-12, 1996, vol. 11, p. 492 (abstract no. Pub.D.1348). A child-to-adult programme targeting the family was initiated. Children aged 5-10 years were targeted to act as pressure group/change agents. Some children were equipped with facts about HIV/AIDS transmission and spread with particular emphasis on risky practices of parents. The message was given to the children in form of songs and stories to communicate to their parents. Results: The programme is steadily succeeding, with more children getting involved and more parents changing their behaviour. The lesson learned is that empowered children can be instrumental in the fight against AIDS for they create and instil a sense of concern in their parents that results in behaviour change, hence reducing risky practices and consequently the spread of HIV.
- 7 Barnett, J., *Security and Climate Change*, October 2001, p. 12.
- 8 Smith, D. and J. Vivekananda, *A Climate of Conflict: The links between climate change, peace and war*, November 2007, p. 3.
- 9 Office of the Special Representative for Children and Armed Conflict, <www.un.org/children/conflict/english/issues.html>.
- 10 IPCC, Fourth Assessment Report, *Climate Change: The physical science basis*, 2007.
- 11 UNICEF, *Climate Change and Children*, op. cit., p. 6.
- 12 IPCC, Fourth Assessment Report, Working Group II, *Impacts, Adaptation and Vulnerability, Policymakers Summary*, 2007, <www.ipcc.ch/pdf/assessment-report/ar4/syr/ar4_syr_spm.pdf>, p. 6.
- 13 UNEP, *Global Environment Outlook: Environment for development (GEO-4)*, 2007.
- 14 IPCC, Fourth Assessment Report, *Climate Change: The physical science basis*, 2007.
- 15 UNICEF, *The State of the World's Children 2008*, Table 6, p. 137.
- 16 United Nations Economic and Social Affairs, Population Division, <<http://esa.un.org/unpp/p2k0data.asp>>.
- 17 Calculated from data in United Nations Department of Economic and Social Affairs, *World Population Prospects: The 2006 revision*, vol. II - Sex and Age Distribution of the World Population, United Nations, New York, 2007.
- 18 United Nations General Assembly, World Youth Report 2005, Report of the Secretary-General, A/60/61, E/2005/7, 6 December 2004.
- 19 IPCC, *Climate Change 2007: Synthesis Report - Summary for Policymakers*, p. 11.
- 20 For example, WHO lists climate change as one of the causes of increasing malaria burden in Africa. WHO, *Africa Malaria Report*, 2003. Source: Campbell-Lendrum, D. and R. Woodruff, 'Climate change: Quantifying the health impact at national and local levels', Environmental Burden of Disease Series, no. 14, WHO, 2007.
- 21 Mathieu-Nolf, M., 'Poisons in the Air: A cause of chronic disease in children', *Journal of Toxicology - Clinical Toxicology*, vol. 40, no. 4, 2002, p. 483.
- 22 Kempe, R., H., 'Child survival, poverty, and labor in Africa', *Journal of Children & Poverty*, 2005, vol. 11, no. 1, pp. 19-42.
- 23 Barker, D.J.P., 'Maternal nutrition, fetal nutrition, and disease in later life', *Nutrition*, September 1997, vol. 13, no. 9, pp. 807-813; Victoria C.G. et al., Maternal and Child Undernutrition Study Group, 'Maternal and Child Undernutrition: Consequences for adult and human capital, 2008', *The Lancet*, vol. 371, 2008, pp. 40-57; Crimmins, E. and C. Finch, 'Infection, inflammation, height, and longevity', *Proceedings of the National Academy of Sciences*, vol. 103, no. 2, 2006, pp. 498-503.
- 24 Bartlett, S., 'Climate Change and Urban Children Impacts and Implications for Adaptation in Low and Middle Income Countries', IIED Human Settlements Discussion Paper, (forthcoming), p. 11, <www.iied.org>.
- 25 Iltus, S., *Community-Based Research and Participatory Planning with Children and Communities in the Villages of Rumbek, South Sudan*, Save the Children Sweden, 2007.
- 26 Goodman, D., Child Participation in Water, Environment and Sanitation (WES) in Tajikistan, UNICEF WES/PD, 2004.
- 27 Bartlett, S., Climate Change and Urban Children Impacts and Implications for Adaptation in Low and Middle Income Countries, op. cit.

- 28 UNICEF, *The State of the World's Children* 2003, p. 44.
- 29 The Gleneagles Communiqué: "(e) Around 2 billion people lack modern energy services. We need to work with our partners to increase access to energy if we are to support the achievement of the goals agreed at the Millennium Summit in 2000."
- 30 WHO, *Fuel for life, household energy and health*, 2006, p. 20.
- 31 Ibid.
- 32 WHO, *Fuel for life, household energy and health*, op. cit.; and UNICEF, *Climate Change and Children*, op. cit., 2007, p. 17.
- 33 Douglas, I. et al., 'Unjust Waters: Climate change, flooding and the urban poor in Africa', ref. from Stephens, C. et al., *Environment and Health in Developing Countries: An analysis of intra-urban differentials*, London School of Hygiene and Tropical Medicine, 1994; and also Stephens, C., 'Healthy Cities or Unhealthy Islands: The health and social implications of urban inequality', *Environment and Urbanization*, vol. 8, no. 2, October 1996, pp. 9-30.
- 34 Eriksen, S., 'Linkages between climate change and desertification in East Africa', *Arid Lands Newsletter*, No. 49, May/June 2001, <<http://ag.arizona.edu/OALS/ALN/aln49/eriksen-part1.html>>.
- 35 For example, in 2001, 1.96 million people died from infectious diarrhoea; 1.3 million were children under five. <www.unesco.org/water/iyfw2/health.shtml>.
- 36 WHO, 'Children and Malaria' at www.rbm.who.int/cmcc_upload/0/000/015/367/RBMInfosheet_6.htm, accessed 17 February 2008.
- 37 Claeson, M. et al., 'Reducing child mortality in India in the new millennium', *Bulletin of the World Health Organization*, vol. 78, no. 10, 2002, pp. 1192-1199; Timaeus, I., K. Harris and F. Fairbairn, 'Can use of health care explain sex differentials in child mortality in the developing world?' in *Too Young to Die: Genes or gender?*, United Nations, New York, 2008.
- 38 Nelson, V. et al., 'Uncertain Predictions, Invisible Impacts, and the Need to Mainstream Gender in Climate Change Adaptations', *Gender and Development*, vol. 10, no. 2, pp. 51-59.
- 39 Schmuck, H., 'Empowering women in Bangladesh', 2002. <<http://www.reliefweb.int/rw/rwb.nsf/AIIDocsByUNID/570056eb0ae62524c1256b6b00587224>>, accessed 3 November 2008.
- 40 Cannon, T., 'Gender and Climate Hazards in Bangladesh', *Gender and Development*, vol. 10, no. 2, 2002, pp. 45-50.
- 41 Even though the Asian tsunami was not related to climate change, the mortality and injury figures are very interesting since they provide solid information on the disproportionate vulnerability of children in extreme climatic events and disasters.
- 42 Doocy, S. et al., 'Tsunami Mortality Estimates and Vulnerability Mapping in Aceh, Indonesia', *American Journal of Public Health*, vol. 97, 2007, pp. S146-S151.
- 43 UNDP, *Human Development Report 2007/2008*, 'Fighting Climate Change: Human solidarity in a divided world', p. 166.
- 44 UN, UN System Chief Executives Board (CEB), *A Proposed UN System-Wide Approach to Climate Change*, 27 October 2007.

2

IMPACTS OF CLIMATE CHANGE ON CHILDREN

2.1 Existing vulnerabilities and environmental health risks

From the antenatal stage onwards, children are exposed to constant environmental threats to their health and well-being. These threats exist in all environments – in developing and industrialized countries, in rural and urban areas, and everywhere children live, learn and play. Many children, especially those in developing countries, stand on the front line of poverty, pollution and resource degradation.

Children are affected by unsafe environments in many ways: They may die from environment-related illness; those weakened by such illnesses are more susceptible to undernutrition and opportunistic infections; and their physical and mental development may be permanently stunted. An estimated 36 per cent of deaths in children younger than 14 years are attributed to illness and conditions related to poor environments. The largest burden is attributed to diarrhoea,¹ which kills at least 1.9 million children under five annually² and sickens tens of millions more.

Undernutrition and malaria are two of the other major killers of children. **Undernutrition** is the underlying cause of at least 3.5 million deaths annually and more than one third of deaths in children under five years of age.³ It contributes to children's vulnerability to a number of other diseases and illnesses. **Malaria** causes an estimated 1 million deaths each year, and around 80 per cent of these are among children under five.⁴ In sub-Saharan Africa alone, more than 2,000 children under five die each day from malaria.⁵ These conditions, like diarrhoea, are highly sensitive to climatic conditions.⁶

Climate change is expected to intensify these combined threats to children and is also likely to accelerate certain large-scale environmental changes, including desertification, diminishing freshwater resources and biodiversity loss, which have far-reaching effects on child health and well-being.

2.2 Key climate changes and their impacts

Figure 2.1 (*page 10*), Impacts of climate change on children,⁷ is based on direct impacts of climatic events on the physical environment, generating a range of conditions that are potentially devastating for families and children. Most of these changes are chronic and debilitating, like deforestation, desertification and drought. Gradual deterioration of the physical environment is less visible when compared to sudden-onset disasters, and in many cases, their relationship to climate change is harder to track and make it more difficult to generate necessary attention from the international community.⁸

Rising sea levels and shrinking glaciers

Shrinking glaciers and rising sea levels will pose new risks for human security. The retreat of glaciers will bring the danger of short-term flooding and long-term declines in water availability across Asia, Latin America and parts of East Africa.⁹ Rising sea levels will reduce the availability of fresh water, affecting millions of people in low-lying countries and river deltas.¹⁰

Populations in a number of countries are at significant risk to the effects of rising sea levels, with large numbers of poor people often living in low-lying coastal areas. Floods and overflowing of sea defences lead directly to emergency conditions, and saltwater intrusion can threaten potable water supplies.¹¹

Children living in substandard housing on low flood plains are at high risk of drowning, since they are less likely to be able to swim and are dependent on adults during an emergency. For example, the 2003 Bangladesh Health and Injury Survey of more than 171,000 households established that drowning is the single leading cause of death among children aged 1-18, having overtaken pneumonia and diarrhoea. According to the survey, nearly 17,000 children in Bangladesh drown each year, and about four times as many, over 68,000 children, nearly drown.¹²

Heavy precipitation, flooding and water security

In poor urban areas, floods can create severe and widespread unsanitary conditions. Thousands, including many children, died as a result of the 2005 floods in Mumbai, India, and the inadequate drainage and sewer network was largely blamed. Since 2002, floods in 80 countries have killed more than 3,000 people and affected the lives of 17 million.¹³ During the period 1973 to 1997 an estimated 66 million people worldwide suffered from flood damage. In 1998 alone the death toll from floods was almost 60,000.¹⁴

Immediate health impacts of floods include drowning, injuries, and physical and mental trauma. Severe flooding in the Sarlahi District of Nepal shows that the flood-related fatality rates for children were six times higher than mortality rates in the same villages a year before the flood. Flood-related fatality rates in the recorded population were 13.3 per 1,000 for girls and 9.4 per 1,000 for boys, 6.1 per 1,000 for women and 4.1 per 1,000 for men. Children, particularly girls, were at highest risk of flood-related fatality; in this population, children aged between 2 and 9 years were twice as likely to die as their same-sex parent.¹⁵ Longer-term effects of flood include increases in communicable diseases such as those caused by ingestion of contaminated water (e.g., cholera and hepatitis A) or contact with contaminated water (e.g., leptospirosis).¹⁶

Rising temperatures, droughts and desertification

By mid-century, the land area affected by drought is expected to increase. Water resources in these affected areas could decline as much as 30 per cent. Droughts exacerbate desertification, which is already happening across one third of Earth's landmass and costing the world an estimated US\$42 billion in lost production.¹⁷ Desertification is associated with food and water insecurity, undernutrition and elevated infant mortality.

In Ethiopia and Kenya, two of the world's most drought-prone countries, children aged five or under are respectively 36 and 50 per cent more likely to be malnourished if they were born during a drought. For Ethiopia, that translated into some 2 million additional malnourished children in 2005. In Niger, children aged two or under born in a drought year were 72 per cent more likely to be stunted. Indian women born during a flood in the 1970s were 19 per cent less likely to have attended primary school.¹⁸

A long drought followed by an intense rainfall usually generates multiple disease outbreaks. During droughts, water availability is diminished, and water quality is often degraded, as people share water with livestock. A drought followed by flooding also encourages rodents and rodent-borne disease outbreaks as rodent populations boom in the wake of replenished water supplies.¹⁹

Desertification affects 93 per cent of Morocco's territory. Ever-increasing periods of drought exacerbate the process mainly because the soil is highly vulnerable to erosion and the fragile living

conditions of rural populations have led to overexploitation of natural resources, leading to further degradation of the environment.²⁰

Per capita food production in the country has fallen steadily since the 1930s. Morocco now faces a food security crisis. In 1981 and 1984, the country was shaken by insurgence and rioting related to the lack of food security, disturbing the lives of many children and families.²¹

In a study of 51 post-emergency camps established after disasters in seven countries, the quantity of water available was shown to be directly related to the mortality rates of children under five. Camps with greater water availability had significantly lower mortality rates.²²

A review of existing global patterns and the dynamics of the water resource system indicate significant impacts of drought, with projections of increases in the areas affected by drought.²³

Extreme weather events

Extreme weather events such as cyclones, floods and droughts are among the well-established consequences of climate change. The scale of these events is enormous. Over the last 30 years, 2,156 floods were recorded, causing 206,303 human deaths and impacting some 2.6 billion people worldwide. The statistics clearly show the disproportional vulnerability of children to climatic events. Overall, 25 per cent of deaths in the population can be attributed to environmental factors. Among children under 14, however, the figure rises to 36 per cent.²⁴

Deforestation

Deforestation is the extensive cutting down or burning of trees and forest – mainly for timber and fuel, or to clear land for other uses, such as agriculture, ranching, mining or building. It is a major contributor of greenhouse gas emissions to the atmosphere and a threat to sustainable development. Healthy forests are critical to food security and the sustainable livelihoods of an estimated 1.6 billion people globally, including about 60 million indigenous people who are almost wholly dependent on forests.²⁵

Biodiversity

Biodiversity refers to the variety of species on Earth and the many interactions between them. Climate change is already weakening a number of fragile ecosystems, and forcing species to adapt by shifting habitat, changing life cycles, or developing new physical traits. Species that are unable to adapt face extinction.

Child health depends on the continuous supply of various ecological services, which are underpinned by biodiversity.²⁶ Biodiversity loss will directly and seriously undermine child health and well-being. One of the biggest impacts will be on food production and livelihoods. For example, in India, significant numbers of local families and economies rely on forest biodiversity. Similarly, the loss of biodiversity

in the coral reefs of the Philippines most probably affects fishing communities, contributing to household poverty and child undernutrition.²⁷

2.3 Implications for child health and well-being

Food security and undernutrition

Undernutrition is the underlying cause of at least 3.5 million deaths each year, and of more than one third of deaths in children under five years of age.²⁸ It contributes to children's vulnerability to a number of other diseases and illnesses. Undernutrition may be exacerbated by more frequent or severe extreme weather events caused by climate change, resulting in losses in biodiversity, desertification and deforestation.²⁹

Food production could decline by as much as 50 per cent by 2020, causing widespread child undernutrition.³⁰ Loss of food security, as recently manifested in increasing food prices and the scarcity of staple foods such as grains and rice, will be a growing concern, particularly for the poor. Chronic droughts, floods and diversion of grains for biofuel production are diminishing food production, causing the loss of livelihoods for millions of families.³¹

Undernutrition, inextricably associated with drought and poverty, is a major risk factor for disease,³² as it lowers resistance.³³ But the relationship between nutrition and diseases is bi-directional – not only does disease bring undernutrition, but undernutrition also predisposes its sufferers to diseases.³⁴ For example, a study of growth patterns in Papua New Guinea indicates that in populations where undernutrition is still common, infection has become more important than primary undernutrition as the initiator of growth-faltering, due to undernutrition-infection interactions.³⁵

The nutritional status of children is also closely related to their vulnerability to malaria, with poor nutrition often causing deaths from infections that would not otherwise be fatal.³⁶ Nutrition hence must not be overlooked as part of the actions taken to protect child health from the adverse effects of climate change. Diarrhoea, malaria and respiratory diseases have aggravating effects on children when exacerbated by undernutrition.³⁷

Water security, diarrhoea and other waterborne diseases

Waterborne diseases and diarrhoea are expected to increase with climate change. As the temperatures rise, the replication of the pathogens that water carries (protozoa, bacteria and viruses) will also increase.³⁸ Children have much more frequent contact with water than adults (for example, from playing outside), and their metabolism is more sensitive.

Diarrhoeal disease is one of the leading causes of child death. Almost 2 million children under five die each year from diarrhoea.³⁹ The majority of diarrhoeal deaths are attributable to unsafe drinking water and lack of basic sanitation. Numerous studies have established a strong link between diarrhoea, ambient

temperature and amount of rainfall in developing countries. For example, a study in Bangladesh found that the number of non-cholera diarrhoea cases per week increased by 5.1 per cent for every 10mm increase above the threshold of 52mm of average rainfall. The number of cases also increased by 3.9 per cent for every 10mm decrease below the same threshold of rainfall.⁴⁰ The outbreak is mediated by the quality of water and sanitation coverage.⁴¹

Malaria and other vector-borne diseases

Malaria causes more than a million deaths each year, up to 80 per cent of which are among children under five.⁴² Most malaria cases and deaths are in sub-Saharan Africa. However, Asia, Latin America, the Middle East and parts of Europe are also affected.

With increasing temperatures, malaria is returning to places where it was once eradicated. For example, after 50 years of little incidence, malaria is being reported in the highlands of Kenya. This is after subtle increases in temperature.⁴³ There are various studies that model and estimate the impact of climate change on future transmissions of malaria.⁴⁴ These forecasts have been supplemented by studies using community data. For example, for clinical malaria among children under five in Kenya, the temperature was found to be the best predictor.⁴⁵

Vector-borne diseases, including malaria, dengue fever, yellow fever and schistosomiasis, are likely to increase as their vectors are affected by the changing climate.

Death and illnesses from use of biomass fuels indoors

Indoor air pollution from biomass fuels is a major risk factor for sickness and death in children.⁴⁶ In the homes of the poor where there is not enough ventilation and smoky conditions exist, children are exposed to poor air for long periods of time. It is estimated that 2.1 million children under five die from acute respiratory illnesses worldwide.⁴⁷

As global energy demand brings an increase in the burning of fossil fuels, air quality is likely to drop in many areas, including rural areas, where people use biomass fuels in the home. Children are more vulnerable to air pollution than adults, as their bodies are growing and their lungs are developing. They breathe at a faster rate than adults and spend more time outdoors playing and running, thus exposing themselves to a higher degree of air pollution.⁴⁸

Climate change is an important determinant of the incidence of asthma. A study explored several variables associated with asthma-related hospital visits by children in Tokyo. It was determined that 36 per cent of the visits were explained by 12 distinct climatic factors.⁴⁹

Impacts from the breakdown of economic and social structures

A decline in a child's access to education is closely linked to the breakdown of social and economic structures. One very common reason for non-attendance is the deterioration of child health and

nutritional status. For example, undernutrition strongly affects primary school enrolment in Ghana.⁵⁰ Similarly, in Kenya, a deworming programme was shown to be the most cost-effective intervention to increase primary school enrolment.⁵¹ Loss of livelihoods and food security also prevent access to education for many children. In the coastal communities of Azerbaijan, for example, the rising sea level of the Caspian Sea resulted in a very significant drop in school attendance. Focus groups conducted with residents indicated that relocation of the schools due to the sea level rise, together with deteriorating health of the children, departure of the teachers due to economic reasons, and financial problems of the families, were the primary reasons for the drop in school attendance.⁵²

A clear consequence of climate change is **displacement and migration of families**. Displacement, migration and emergency situations almost always have a negative impact on children. They increase the possibility of child abuse and trafficking. In the aftermath of disasters, children may be pulled out of school and put to work to help their families recover. Their education and health suffer accordingly. The long-term negative effects of extended periods of labour may be irreversible for many children.⁵³ Disasters have also been linked to child maltreatment, through increased parental stress and decreased social supports.⁵⁴

Displaced poor families usually end up living on the periphery of urban areas. The locations usually have very poor infrastructure, are close to industry and toxic waste, and provide substandard housing conditions. In this context, Save the Children UK estimates that millions of children will be killed, forced to flee their homes and placed at risk from hunger, disease and physical or sexual abuse.⁵⁵

Some of the most dramatic consequences of cultural uprooting can be seen when indigenous children and their families migrate from their home communities to other areas, including in many cases to urban settings.

The **economic impacts** of climate change are anticipated to be substantial. The Stern Review estimates that the outcome of carrying on with business as usual would be “catastrophic”; resulting in an economic collapse akin (in today’s money) to the cost of fighting the two world wars and the 1930s stock market crash combined.⁵⁶ Economists have predicted that given the strong correlations between growth and poverty reduction, and between reduced income and child mortality, a climate-driven reduction in national gross domestic product would increase the number of people below the US\$2 a day poverty line, and thus raise child mortality rates (compared to a world without anthropogenic climate change). This impoverishment would mean lower public and private expenditures on goods that improve health, such as safe water, food, education and basic sanitation.⁵⁷

One of the most pronounced impacts of climate change is the loss of livelihoods for millions of families.⁵⁸ The direct impact of the loss of food security is high levels of undernourishment in children, and a clear link has been established between nutritional status and learning in school.⁵⁹

In addition to food security, deteriorating economic conditions force mothers to work longer hours and reduce the amount of time spent with their children. A West Africa study established the link between child mortality and the time a mother spends on labour rather than on childcare.⁶⁰

NOTES

- 1 Prüss-Üstün, A. and C. Corvalán, ‘Preventing Disease Through Healthy Environments: Towards an estimate of the environmental burden of disease’, WHO, Geneva, 2006.
- 2 Various WHO sources, including Parashar, U. D., J. Bresee and R. Glass, ‘The global burden of diarrhoeal disease, as estimated from studies published between 1992 and 2000’, *Bulletin of the World Health Organization*, vol. 81, no. 4, 2003, p. 236.
- 3 Black, R.E. et al., Maternal and Child Undernutrition Study Group, ‘Maternal and Child Undernutrition: Global and regional exposures and health consequences’, *The Lancet*, vol. 371, no. 9608, January 2008, pp. 243-60.
- 4 UNICEF, *Progress for Children: A world fit for children statistical review*, no. 6, 2007, p. 36.
- 5 UNICEF and Roll Back Malaria Partnership, ‘Malaria and Children: Progress in intervention coverage’, 2007, p. 1, 7.
- 6 WHO, <www.who.int/mediacentre/factsheets/fs284/en/index.html>.
- 7 This diagram attempts to reflect existing consensus knowledge and understanding of the impacts of climate change and their implications for children, taking into consideration different frameworks and means of depiction that appear in the literature. Particular acknowledgement is given to the framework presented in Back, E. and C. Cameron, ‘Our Climate, our Children, our Responsibility: The implications of climate change for the world’s children’, 2008, UNICEF United Kingdom, London.
- 8 Bartlett, S., ‘Climate Change and Urban Children Impacts and Implications for Adaptation in Low and Middle Income Countries’, op. cit., p. 47.
- 9 Briscoe, J., 2005, World Water Assessment Programme, 2006.
- 10 UNDP, *Human Development Report 2006*, ‘Beyond Scarcity: Power, poverty and the global water crisis’, p. 159.
- 11 The conditions presented in this paragraph are described in ‘Guyana: Proposal for action to protect children from environmental degradation due to global warming’, 2008.
- 12 Rahman, A. et al., Bangladesh Health and Injury Survey Report on Children, January 2005, <www.unicef.org/bangladesh/Bangladesh_Health_and_Injury_Survey-Report_on_Children.pdf>.
- 13 Gautam, K. P. and E. E. van der Hoek,, ‘Literature Study on Environmental Impact of Floods’, GeoDelft, June 2003.
- 14 Douben, N., Flood Management Lecture Notes, HH 510/02/1IHE, 2002, Delft, The Netherlands.
- 15 Pradhan, E. K. et al., ‘Risk of flood-related mortality in Nepal’, *Disasters*, vol. 31, no. 1, 2007, pp. 57-70.
- 16 Patz, J. A. and M. Khaliq, ‘Global Climate Change and Health: Challenges for future practitioners’, *Journal of the American Medical Association*, vol. 287, no. 17, 2002, pp. 2283-2284.
- 17 UNEP, *Tunza Magazine for Youth*, vol. 4, no. 1, p. 4.
- 18 UNDP, *Human Development Report 2007/2008*, p. 9.

- 19 Tibbetts J., 'Driven to Extremes: Health effects of climate change', *Environmental Health Perspectives*, vol. 115, no. 4, 2007, pp. A196-203.
- 20 *Implementing the United Nations Convention to Combat Desertification in Africa: Ten African experiences*, UNCCD Report, 2006, p. 24.
- 21 Swearingen, W. D., 'Drought hazard in Morocco', *Geographical Review*, vol. 82, no. 4, 1992, p. 401.
- 22 Spiegel, P. et al., 'Health Programmes and Policies Associated with Decreased Mortality in Displaced People in Post-emergency Phase Camps: A retrospective study', *The Lancet*, vol. 360, no. 9349, 2002, p. 1927.
- 23 Bates, B. et al. (eds.), 'Climate Change and Water', Technical Paper of the Intergovernmental Panel on Climate Change, IPCC Secretariat, Geneva, 2008.
- 24 Prüss-Üstün, A. and C. Corvalán, 'Preventing Disease Through Healthy Environments', op. cit.
- 25 Jansen, Maaïke, UNEP, Children's Environmental Health chapter in UNICEF/WHO/UNEP document (forthcoming in 2008).
- 26 Bernstein, A., 'Health Implications of Biodiversity', *Encyclopedia of Public Health*, (forthcoming).
- 27 Gjertsen, H., 'Can Habitat Protection Lead to Improvements in Human Well-Being? Evidence from Marine Protected Areas in the Philippines', *World Development*, vol. 33, no. 2, 2005, pp. 199-217.
- 28 Black, R.E. et al., 'Maternal and Child Undernutrition', op. cit.
- 29 Akachi, Y. et al., *Global Climate Change and Child Health: A review of the literature*, UNICEF IRC (forthcoming).
- 30 IPCC, Fourth Assessment Report, 2007.
- 31 Ibid., pp. 58, 83.
- 32 Lopez, A. D. et al., 'Global and Regional Burden of Disease and Risk Factors, 2001: Systematic analysis of population health data', *The Lancet*, vol. 367, no. 9524, May 2006, pp. 1747-1757.
- 33 Scrimshaw, N., 'Historical concepts of interactions, synergism and antagonism between nutrition and infection', *Journal of Nutrition*, vol. 133, no. 1, 2003, pp. 316S-321S.
- 34 Scrimshaw, N., 'Historical concepts of interactions, synergism and antagonism between nutrition and infection', op. cit.; and Victora, C.G. et al., 'Pneumonia, Diarrhea and Growth in the First 4 Years of Life: A longitudinal study of 5914 urban Brazilian children', *American Journal of Clinical Nutrition*, vol. 52, 1990, pp. 391-396.
- 35 Ulijaszek S., 'Nutrition, infection, and child growth in Papua New Guinea', *Collegium Antropologicum*, vol. 24, no. 2, 2000, pp. 423-429.
- 36 'Millions of Children Could Be Saved With Better Nutrition', *Nutrition Today*, vol. 39, no. 4, 2004, p. 152-153.
- 37 Friedman, J. F. et al., 'Malaria and Nutritional Status Among Pre-school Children: Results from cross-sectional surveys in western Kenya', *American Journal of Tropical Medicine and Hygiene*, vol. 73, no. 4, 2005, pp. 698-704; Mirshahi, S., et al., 'Prevalence of Exclusive Breastfeeding in Bangladesh and its Association with Diarrhoea and Acute Respiratory Infection: Results of the multiple indicator cluster survey 2003', *Journal of Health, Population and Nutrition*, vol. 25, no. 2, June 2007, pp. 195-204.
- 38 Woodruff, R. and A.J. McMichael, 'Climate Change and Human Health: All affected, but some more than others', *Social Alternatives*, vol. 23, no. 4, 2004, pp. 17-22.
- 39 UNICEF, *The State of the World's Children 2008: Child Survival*, UNICEF, New York, p. 15.
- 40 Masahiro, H. et al., 'Association Between Climate Variability and Hospital Visits for Non-Cholera Diarrhoea in Bangladesh: Effects and vulnerable groups', *International Journal of Epidemiology*, vol. 36, no. 5, 2007, pp. 1030-1037.
- 41 Campbell-Lendrum, D. and R. Woodruff, 'Climate change: Quantifying the health impact at national and local levels', op. cit.
- 42 UNICEF, *Progress for Children: A world fit for children statistical review*, p. 36.
- 43 Alsop, Z., 'Malaria returns to Kenya's highlands as temperatures rise', *The Lancet*, vol. 370, no. 9591, 2007, pp. 925-926.
- 44 See, for example: Rogers, D. J. and S. E. Randolph, 'The global spread of malaria in a future, warmer world', *Science*, vol. 289, 2000, pp.1763-1766; Van Lieshout, M. et al., 'Climate Change and Malaria: Analysis of the SRES climate and socio-economic scenario', *Global Environmental Change*, vol. 14, 2004, pp. 87-99; Sutherst, R. W., 'Global change and human vulnerability to vector-borne diseases', *Clinical Microbiology Reviews*, vol. 17, 2004, pp. 136-173.
- 45 Ye, Y. et al., 'Effect of Meteorological Factors on Clinical Malaria Risk Among Children: An assessment using village-based meteorological stations and community-based parasitological survey', *BMC Public Health*, vol. 7, 2007, p. 101.
- 46 Emmelin, A. and S. Wall, 'Indoor Air Pollution: A poverty-related cause of mortality among the children of the world', *CHEST*, vol. 132, no. 5, 2007, pp. 1615-1623.
- 47 UNICEF, *Progress for Children No. 6*, UNICEF, New York, p. 22.
- 48 Kim, J. J., American Academy of Pediatrics, Committee on Environmental Health, 'Ambient Air Pollution: Health hazards to children', *Pediatrics*, vol. 114, 2004, pp. 1699-1707.
- 49 Hashimoto, M. et al., 'Influence of climate factors on emergency visits for childhood asthma attack', *Pediatrics International*, vol. 46, no. 1, 2004, pp. 48-52.
- 50 Glewwe, P. and H. Jacoby, 'An economic analysis of delayed primary school enrollment and childhood malnutrition in a low income country', *Review of Economics and Statistics*, vol. 77, no. 1, 1995, pp. 156-69.
- 51 Miguel, E. and M. Kremer 'Worms: Identifying impacts on education and health in the presence of treatment externalities', *Econometrica*, vol. 72, no. 1, 2004, pp. 159-217.
- 52 Kudat, A., A. Musayev and B. Ozbilgin, 'Social Assessment of the Azerbaijan National Environmental Action Plan: A focus on community responses to the Caspian Sea environmental disaster', *Social Development Papers*, Paper No. 32, July 1999.
- 53 Huebler, F., Child labor and school attendance in Bolivia, International Education Statistics, <<http://huebler.blogspot.com/2006/06/child-labor-and-school-attendance-in.html>>.
- 54 Ibid.
- 55 Save the Children, *Legacy of Disasters: The impact of climate change on children*, Save the Children UK, London, 2007.
- 56 As quoted in *The Ecologist*, <http://www.theecologist.org/archive_detail.asp?content_id=684>.
- 57 Stern, N. (ed.), *The Economics of Climate Change: The Stern Review*, Part II, 2007, pp. 54-56.
- 58 Ibid., pp. 58, 83.
- 59 UNDP, *Human Development Report 2007/2008*, pp. 79, 89.
- 60 Watson R.T., M. C. Zinyowera and R. H. Moss, Summary for Policymakers, The Regional Impacts of Climate Change: An assessment of vulnerability, A Special Report of IPCC Working Group II, published for IPCC, 1997.

3

THE BASES FOR ACTION: RIGHTS, INSTITUTIONS AND GUIDING PRINCIPLES

3.1. Human rights and the environment

We will not enjoy development without security, we will not enjoy security without development, and we will not enjoy either without respect for human rights. Unless all these causes are advanced, none will succeed.

– In larger freedom: Towards development, security and human rights for all, Report of the Secretary-General of the United Nations, A/59/2005, 21 March 2005

The call to preserve and protect the human rights of all children within legislative, policy and resource allocation decisions at international, regional and national levels requires an understanding of the many linkages between protection of human rights and protection of the environment that have long been recognized.

A number of international and regional treaties and instruments are relevant to issues related to climate change and children, most notably: the 1972 UN Conference on the Human Environment Declaration, the 1992 Rio Declaration on Environment and Development (Principle 10, on access to information, participation and effective remedies) that has played an important role in fostering connections between human rights and environmental approaches at the national level; the Convention on the Rights of the Child; the Aarhus Convention, which covers the European region;¹ article 6 of the UN Framework Convention on Climate Change; the Hyogo Framework for Action 2005-2015; and the Millennium Development Goals.

In relation to substantive matters, a growing body of case law from many national jurisdictions is clarifying the linkages between human rights and the environment, in particular by:

- (1) recognizing the right to a healthy environment as a fundamental human right
- (2) allowing litigation based on this right and facilitating its enforceability in domestic law by liberalizing provisions on standing

- (3) acknowledging that other human rights recognized in domestic legal systems can be violated as a result of environmental degradation.²

Globally, some human rights treaties include the value of the environment in their systems of protection. Among these are the Convention on the Rights of the Child and the International Labour Organization (ILO) Convention No. 169 concerning Indigenous and Tribal Peoples in Independent Countries. At the regional level, the African Charter on Human and Peoples' Rights and the 'Protocol of San Salvador' to the American Convention on Human Rights expressly recognize the right to live in a healthy or satisfactory environment.³

The cross-cutting effect of unsafe and unhealthy environments was conclusive in the findings of a study by the UN Environment Programme (UNEP) and the Office of the High Commissioner for Human Rights (OHCHR), reporting: "In nearly every instance, the complaints brought have not been based upon a specific right to a safe and environmentally-sound environment, but rather upon rights to life, property, health, information, family and home life. Underlying the complaints, however, are instances of pollution, deforestation, water pollution and other types of environmental harm. It may be asked whether or not a recognized and explicit right to a safe and environmentally sound environment would add to the existing protections and further the international values represented by environmental law and human rights."⁴

There is broad recognition that poverty is at the centre of a number of human rights violations and is at the same time a major obstacle to achieving sustainable development and environmental protection. A rights-based approach can enhance the impact of policies and programmes at national and international levels on this matter.

3.2 Convention on the Rights of the Child

The Convention on the Rights of the Child is an important point of reference. It is in force in virtually every country of the world and provides strong direction in several relevant areas, including in respect to children's rights to health, adequate nutritious food and clean drinking water, in the prevention of accidents and the risks of environmental pollution, and in the promotion of education designed to develop respect for the natural environment.

The Convention further specifies general principles that guide considerations of any children's rights issues. These are pertinent to the issue of climate change and children. They include:

- The **protection of children from any form of discrimination** and the need to provide priority attention to the most vulnerable groups of children and to the reduction of existing disparities; this dimension will also call for consideration of the situation of children in different age groups as well as gender dimensions (article 2).
- The **best interests of the child**, expected to be a guiding concern in all decisions that may have an impact on children – including when laws are enacted and enforced, policies are shaped and implemented, and resources are mobilized and allocated (article 3).
- The **promotion of the child's right to life, survival and development** to the maximum extent possible (article 6).
- The **respect of the views of the child** and the involvement of children in decisions affecting their lives (*article 12*).
- The provision of (access to) **adequate nutritious foods and clean drinking water, taking into consideration the dangers and risks of environmental pollution** (article 24, 2(c)).
- The assurance that all segments of society, in particular **parents and children, are informed, have access to education** and are supported in the use of basic knowledge of **child health and nutrition**...environmental sanitation and the prevention of accidents (article 24, 2(e)).

Important reference points are provided by the general measures of implementation of the Convention. They are cross-cutting and affect the overall realization of children's rights. They address:

- The development of **an effective legal system** to safeguard children's human rights and to provide effective remedies in case they are violated or neglected.
- The establishment of **independent child rights institutions**, empowered to promote children's rights, to listen to and make known children's concerns.
- The promotion of a **strategic national agenda on children**, within which climate change dimensions are also addressed.

- The promotion of **effective governmental coordination** of child-related policies and actions, avoiding overlap and gaps in governmental action, and promoting the steady narrowing of disparities and reduction of pockets of exclusion.
- The promotion of **allocation of resources for children** to the maximum extent of available resources (article 4, 'Maximum extent' in the intergenerational context).
- The development of **monitoring tools** to assess change and promote the progressive improvement of children's situations, including among the most vulnerable and socially excluded (for instance through child impact assessments).
- The promotion of **education, information and awareness-raising** on children's rights, including on climate change dimensions.
- The **involvement of civil society and of children** themselves both in the design and monitoring of the implementation of policies on climate change dimensions.⁵

The duty of adults to take children's rights into account is well established. In addition to the Convention on the Rights of the Child, the World Programme of Action for Youth to the Year 2000 and Beyond, 'A World Fit for Children', the United Nations Millennium Declaration, Agenda 21 (adopted at the 1992 'Earth Summit') and other international instruments and treaties all clearly state that children and young people have the right to participate in public life. They further stipulate that families, communities, national leadership and international partners have a responsibility to support this participation and to take children's views into account when discussing issues that affect their lives.⁶ Additional references to the environment and climate change in the Convention are presented in annex C (*page 43*).

3.3 Climate change and the Millennium Development Goals

Table 3.1 summarizes linkages between climate change and the MDGs, as well as proposed child- and youth-centred actions intended to reduce risk and contribute to meeting the goals.

Failure to protect children from the effects of climate change will hinder the world's progress towards the MDGs. According to the *Human Development Report 2007/2008*, climate change is already slowing progress towards the MDGs and increasing inequalities within and across countries. Unless addressed, this trend will cause reversals in sustainable human development in the years ahead.⁷

This has major implications for children. Not only are all of the MDGs critically important and relevant to the lives of children today, but their achievement is also crucial to the world we leave to tomorrow's adults and to future generations. Thus, the call for the concerted engagement of children and young people in efforts to meet and exceed the MDGs is strongly justified.

TABLE 3.1
Climate change and the Millennium Development Goals

Millennium Development Goal	Link to climate change	Adaptation solutions related to children
Goal 1: Eradicate extreme poverty and hunger	<ul style="list-style-type: none"> Climate change is projected to reduce poor people's livelihood assets, for example, health, access to water, homes and infrastructure. Climate change is expected to alter the path and rate of economic growth due to changes in natural systems and resources, infrastructure and labor productivity. A reduction in economic growth directly impacts poverty through reduced income opportunities. In particular in Africa, food security is expected to worsen. 	<ul style="list-style-type: none"> Promote alternative livelihood and small-scale entrepreneurship Vocational training for out-of-school youth and women, related to renewable energy technologies, rainwater catchment, groundwater recharge, and small-scale irrigation environmental cleanup/repairation Community projects such as excavating canals, reducing water logging, raising of embankments
Goal 2: Achieve universal primary education	<ul style="list-style-type: none"> Links to climate change are less direct, but loss of livelihood assets (social, natural, physical, human and financial capital) may reduce opportunities for full-time education in numerous ways. Natural disasters reduce children's available time, while displacement and migration can reduce access to education. 	<ul style="list-style-type: none"> Environmental education Youth-led community mapping of risks and disaster preparedness School-based early warning systems Awareness and advocacy activities School gardening programmes initiated to support nutrition
Goal 3: Promote gender equality and empower women	<ul style="list-style-type: none"> Climate change is expected to exacerbate current gender inequalities. Depletion of natural resources and decreasing agricultural productivity may place additional burdens on women and girls' health and reduce time available to participate in decision-making processes and income-generating activities. Climate-related disasters have been found to impact more severely on female-headed households. 	<ul style="list-style-type: none"> Local community-based water management programmes Community gardens Disaster preparedness and risk reduction Community action to eliminate conflict-inducing environments
Goal 4: Reduce child mortality	<ul style="list-style-type: none"> Direct effects of climate change include increases in heat-related mortality and illness associated with heat waves. Climate change will likely result in declining quantity and quality of drinking water, which is a prerequisite for good health, and exacerbate undernutrition – by reducing natural resource productivity and threatening food security. 	<ul style="list-style-type: none"> Access to health services Household water treatment and oral rehydration therapy Improved access to sanitation and hygiene education
Goal 5: Improve maternal health	<ul style="list-style-type: none"> Children and pregnant women are particularly susceptible to vector- and waterborne diseases. 	<ul style="list-style-type: none"> Strengthening of health services and distribution of malaria pills through schools
Goal 6: Combat HIV/AIDS, malaria and other diseases	<ul style="list-style-type: none"> Climate change may increase the prevalence of some vector-borne diseases and vulnerability to water or food-borne diseases, or diseases transmitted from person-to-person. 	<ul style="list-style-type: none"> Increased vector control and response to waterborne diseases Provision of insecticide-treated mosquito nets Cleaning of stagnant water
Goal 7: Ensure environmental sustainability	<ul style="list-style-type: none"> Climate change will alter the quality and productivity of natural resources and ecosystems, some of which may be irreversibly damaged, and these changes may also decrease biological diversity and compound existing environmental degradation. 	<ul style="list-style-type: none"> Increased access to water and sanitation Tree-planting campaigns School and community gardens Mapping of water sources and sanitation promotion Demand-led approaches to school water supply, sanitation and hygiene
Goal 8: Develop a global partnership for development	<ul style="list-style-type: none"> Climate change is a global issue and the response requires cooperation from all countries, especially to help developing countries adapt to the adverse impacts of climate change. 	<ul style="list-style-type: none"> Better information exchange between governments and non-governmental organizations Build civil society alliances Initiate discussions on the Convention on the Rights of the Child and climate change at all levels

Source: Adapted and expanded from UNDP, UNEP, World Bank, Asian Development Bank (ADB), African Development Bank Group (AfDB), GTZ, UK Department for International Development (DFID), Organisation for Economic Co-operation and Development (OECD), European Commission, Netherlands Development Cooperation, *Poverty and Climate Change: Reducing vulnerability of the poor through adaptation*, launched at the eighteenth session of the Subsidiary Bodies of the UNFCCC in Bonn, Germany, 10 June 2003, p.12.

3.4 Agenda 21 and the Rio Conventions

Agenda 21 and the Rio Declaration on Environment and Development were adopted at the UN Conference on Environment and Development (UNCED) held in Rio de Janeiro, Brazil, in 1992. Principle 10 of the declaration, which states “environmental issues are best handled with participation of all concerned citizens, at the relevant level,” has played an important role in fostering connections between human rights and environmental agendas at the national level.

Three international treaties came out of UNCED: the UN Framework Convention on Climate Change (UNFCCC), the Convention on Biological Diversity, and the Convention to Combat Desertification (UNCCD). Collectively, these are known as ‘the Rio Conventions’. The secretariat of each of the Rio Conventions supports the efforts of Member States to develop and implement national policies to address these environmental threats and risks to human security.

3.5 Aarhus Convention

In Europe, the Convention on Access to Information, Public Participation in Decision-Making and Access to Justice in Environmental Matters (the ‘Aarhus Convention’) explicitly links human and environmental rights, furthers the concept of intergenerational justice, and establishes that sustainable development can only be achieved through the engagement of all stakeholders. Under the Convention’s “three pillars,” the public is entitled to access to information, participation in decision-making, and access to justice (enforcement). Therefore, it is not only an environmental agreement, but it is also a convention about government accountability, transparency and responsiveness – all important elements of the integrated approach needed for the institutional response to the effects of climate change on children. The Preamble states that “every person has the right to live in an environment adequate to his or her health and well-being, and the duty, both individually and in association with others, to protect and improve the environment for the benefit of present and future generations.”⁸

On 20 July 2006, the European Commission published the ‘Communication on youth participation and information in view of promoting young people’s active citizenship’. The communication is a follow-up to the 2001 White Paper, ‘A New Impetus for European Youth’, in which Member States undertook to incorporate the concerns of Europe’s young people in policymaking actions.

The communication conveys three key messages:

- Europe’s young people must have **easy access to information**.
- Measures must be introduced to **encourage civic participation among youth**.
- Member States undertake to work closely together to **encourage the effective participation**

of Europe’s youth through the Open Method of Coordination.⁹

Article 6 of the United Nations Framework Convention on Climate Change

Article 6 of the UNFCCC addresses education, training, public awareness, public participation and access to information in relation to climate change. Its prescriptions are vital in engaging all stakeholders and major groups.

The five-year New Delhi Work Programme was adopted in 2001, aimed at integrating article 6 activities into existing sustainable development and climate change strategies. It set out to build on actions relating to the Convention’s technology transfer and capacity-building frameworks. The Subsidiary Body for Implementation at Conference of the Parties 13 (COP 13) recognized that “the five-year New Delhi Work Programme has proved to be a good framework for action,” and adopted the amended Work Programme for an additional five years. Another review of the Work Programme will be undertaken in 2012, with an intermediate review of progress in 2010, to evaluate its effectiveness and identify emerging gaps.¹⁰

3.6 Partnerships with faith-based organizations

Partnerships with faith-based organizations can provide further effective bases for action. “These are serious stakeholders in development. They are also the oldest institutions in the world and possess wisdom about how to live and how to keep hope alive, which we need to hear and respect.”¹¹

The Alliance of Religions and Conservation, a secular body founded in 1995 by HRH Prince Philip, Duke of Edinburgh, helps the major religions of the world to develop environmental programmes, based on their own core teachings, beliefs and practices. When the Climate Change Partnership Initiative invited the world’s major faiths to lead by example and work in partnership with environmental agencies to determine targets for energy saving and reduction in emissions, the response was far more positive than anyone had anticipated.

Faith-based organizations think in generations, not in 3-, 5- or even 15-year terms. They have the social stability and experience to weather all forms of challenge – from outright persecution to civil war, international conflict and changing economic and social patterns. As a partner to intergovernmental and governmental bodies, they are well placed to support long-term structures and solutions.

3.7 Partnerships with youth organizations

Partner organizations in the Global Movement for Children¹² can be natural associates within an international framework for action to support local

actions of children and young people. The Global Movement is a worldwide network of organizations and people – including children – uniting efforts to build a world fit for children.

A group of child rights organizations and networks are currently working on a number of common initiatives in support of, and as part of the Global Movement. These are the Alliance of Youth CEOs, BRAC, CARE, ENDA (Environmental Development Action in the Third World), the International Save the Children Alliance, the Latin American and Caribbean Network for Children (REDLAMYC), NetAid (an initiative of Mercy Corps), Oxfam, Plan International, UNICEF and World Vision International.

One example is an action research and knowledge-sharing programme on climate change and child partnership called Children in a Changing Climate, which links child-centred development, disaster risk reduction and climate change adaptation approaches. The programme is intended to inform the design and delivery of projects and policies focusing on child-centred climate change adaptation, and enable children to claim their right to a voice on adaptation at every level – from their community to UN climate change negotiations. This programme is supported by a partnership between Plan International, the Institute of Development Studies in the UK, ActionAid, DFID and others.¹³

NOTES

- 1 Meeting of Experts on Human Rights and the Environment, 14-15 January 2002, Final text (16 January 2002), Review section 6, <www2.ohchr.org/english/issues/environment/environ/conclusions.htm>.
- 2 Ibid., Assessment, section 15.
- 3 Ibid., Review section 7.
- 4 Shelton, Dina, UNEP-OHCHR Expert Seminar on Human Rights and the Environment, Background Paper No. 2 'Human Rights and the Environment: Jurisprudence of human rights bodies', 2002, p. 11.
- 5 UNICEF IRC, January 2008.
- 6 UNICEF, International Federation of Red Cross and Red Crescent Societies (IFRC), World Organization of the Scout Movement, World Association of Girl Guides and Girl Scouts, International Youth Foundation, International Award Association, World Alliance of YMCAs, World YWCA, 'Children and Young People: Participating in decision making', 2003, p. 3.
- 7 UNDP, *Human Development Report 2007/2008*, p. 21.
- 8 Convention on Access to Information, Public Participation in Decision-Making and Access to Justice in Environmental Matters, <www.unece.org/env/pp/documents/cep43e.pdf>. Also see 'Human Rights and Environment Issues in Multilateral Treaties Adopted between 1991 and 2001', Background Paper, <www2.ohchr.org/english/issues/environment/environ/bp1.htm>.
- 9 Health and Environment Alliance, <www.env-health.org/a/2241>.
- 10 See <http://unfccc.int/cooperation_and_support/education_and_outreach/items/2529.php>.
- 11 Former World Bank President James D. Wolfensohn in Foreword to *Faith in Conservation: New approaches to religions and the environment*, 2003.
- 12 For more information on the Global Movement for Children, see <www.gmfc.org/>.
- 13 Institute of Development Studies and Plan International, Children in a Changing Climate, <www.plan-uk.org/pdfs/drrclimatechange.pdf>.

4

ADAPTATION AND MITIGATION: COMPLEMENTARY STRATEGIES

We cannot stop natural calamities but we can and must better equip individuals and communities to withstand them.

– Former UN Secretary-General Kofi A. Annan, from a Message on the International Day for Disaster Reduction, 12 October 2005

4.1 Mitigation and adaptation

It is absolutely clear that the changing global environment will impede development efforts, increase risks to public health, frustrate poverty alleviation programmes and exacerbate the rate of migration from water-stressed regions. The human security risks will be greater for the most vulnerable populations, especially children.

Both mitigation and adaptation are needed to significantly reduce the risks and increase the resilience of the world's most vulnerable citizens. Mitigation means taking action to reduce greenhouse gas emissions to avoid further climate change than has already occurred due to historic and current emissions. It is about transforming the way that individuals, governments and industry produce and use energy, changing activities to reduce or eliminate emissions, and developing clean and efficient infrastructure where it does not currently exist. In parallel to mitigation efforts, adaptation to climate change is absolutely essential. The need to adapt has been repeatedly affirmed, including in the Fourth Assessment Report of the IPCC and *The Stern Review* on climate change.¹

In the near term, adaptation actions can reduce the impacts of climate change (although they cannot be reduced to zero). In the longer term, a failure to mitigate climate change will lead to such massive impacts that adaptations will be unsuccessful. Adaptation and mitigation should not be considered as either/or strategies, but rather as complementary ones that should be pursued together.

The cost of taking preventive action now is much lower than paying the price later.² This recognition has led many governments, civil society groups and international organizations to begin to pay more attention to the issues of climate change adaptation.³ For example, the economic benefits resulting from achieving MDG 7, Target 10, to reduce by half the proportion of people without sustainable access to safe drinking water and basic sanitation, include:

- An estimated US\$7.3 billion per year from avoided illnesses⁴
- Almost US\$750 million per year from lower morbidity and mortality⁵
- An estimated US\$64 billion per year from increased production, higher school attendance and more leisure time, all related to having water supplies closer to homes and toilets nearby.⁶

Some examples of the cost-effectiveness of disaster risk reduction

- The World Bank and the United States Geological Survey calculated that global economic losses from disasters during the 1990s could have been reduced by US\$280 billion if \$40 billion had been invested in mitigation and preparedness.
- In China, investment of US\$3.15 billion in flood control measures over 40 years is believed to have averted potential losses of \$12 billion.
- In Viet Nam, 12,000 hectares of mangroves planted by the Red Cross protect 110km of sea dykes. Planting and protection cost US\$1.1 million but has reduced the cost of dyke maintenance by \$7.3 million per year (and the mangroves have protected 7,750 families living behind the dykes).
- According to Oxfam, the value of cattle saved on a flood shelter of four acres in Bangladesh during the 1998 floods was as much as £150,000, against a construction cost of only £8,650.

Sources: Twigg (2002); World Bank (2004); Tearfund (2004c). See also White, P, et al., *Disaster Risk Reduction: A development concern*, DFID, London, February 2004, p. 33.

There is a significant role for official development assistance in financing adaptation measures, including human and institutional capacity-building, and in reducing vulnerability.⁷ By taking incremental interventions now to mainstream climate concerns in development, these impacts on poor people and poor countries will be significantly reduced in the years to come.

Eight key adaptation interventions

Eight key interventions may be identified that will contribute to reductions in human security risks to children:

1. **Household water supply, sanitation and hygiene** – including water treatment, oral rehydration therapy, hygiene education and sanitation.
2. **Groundwater recharge and watershed remediation** – including rainwater harvesting, run-off catchments, watershed clean-ups, tree planting and restoration of biodiversity.
3. **Disaster risk reduction and preparedness** – including risk mapping and evacuation plans.
4. **Environmental protection and restoration** – such as school and community gardens, tree planting and clean up of stagnant water and solid waste.
5. **Renewable energy solutions** – including clean energy for homes, schools, solar and wind water

pumps and clean and efficient household solutions for cooking and heating.

6. **Health-related interventions** – including improvements to basic public health infrastructure, environmental health surveillance, insecticide-treated mosquito nets and malaria prophylaxis and treatment.
7. **Community capacity-building** – including environmental education for child-friendly schools and spaces, microenterprise for women, education for sustainable development, participatory local actions and vocational training/job creation.
8. **Social protection and psychosocial support** – including life skills and conflict resolution, education and other programmes to support livelihoods and community functioning, ‘safety net’ interventions to help prevent dislocation and exploitation of children, and interventions to address family and individual stress and trauma.

The relationship between these interventions and the many climate change impacts on child health and development are presented in Figure 4.1 (page 24). In the figure, the principal strategic points are noted for application of these different interventions, by number.

CASE STUDY

Overcoming the challenges: Youth, governments and other stakeholders respond with new determination in Sierra Leone

Food insecurity, skills deficiencies and problems associated with population growth and increasing urbanization are all challenges faced by large numbers of youth in Sierra Leone. One volunteer programme addresses all of these issues all at once.^a

Through a programme called Youth Engagement and Job Creation through Agriculture, some 15,000 rural young men and women between the ages of 15 and 35 are involved in a major effort to improve food security. At the same time, they are improving their own skills and gaining access to resources, which in turn ensures sustainable livelihoods. The Ministry of Youth and Sports, with assistance from the United Nations Development Programme (UNDP) and United Nations Volunteers (UNV), is meeting these goals simultaneously:

- Youth empowerment and employment. Many subsistence farmers are young people; training and resources that have been passed on to the youth provide them with the means to sustain their businesses and livelihoods, which in turn contributes to their sense of empowerment.
- Rural-urban migration. The programme demonstrates that there are viable livelihood alternatives outside the cities.
- By supporting young people in farming activities, the community-based programme also empowers youth to organize themselves for microenterprise development; facilitates the process of youth empowerment by organizing and supporting various voluntary group projects; establishes networks between engaged youth groups for voluntary experience and best practice sharing; and provides for self-employment for mixed groups of youth farmers in vegetable gardening, food-processing, other agricultural activities and marketing, which will promote recognition of their volunteer actions in the districts. The programme has been successful in proving that young people can be positively engaged in their own development as well as in the development of the nation. This contributes to their sense of empowerment.
- Food security. The programme has proved that young people can manage crops and animals effectively.

^a *World Youth Report*, ‘Young People’s Transition to Adulthood: Progress and challenge’, box 3.6, 2007, <www.un.org/esa/socdev/unyin/documents/wyr07_complete.pdf>.

Addressing the needs of children in local adaptation strategies

Children's needs and problems are not fully understood and addressed during the preparation of adaptation plans, whether national or local. Children should be at the focus of the planning process, which should be carried out in three stages. First, in each community, the potential impacts of climate change on children of all ages must be documented and supported by data whenever possible. This should be done before the development of the adaptation plans. Second, children have to be involved as vocal participants in the planning process. Their needs, concerns and ideas on what will work must be considered throughout this stage. Finally, once the plans are completed, they should be tested to ensure that they are sufficiently addressing children's issues and not creating further negative impacts for children. For example, while trying to improve emergency access to certain parts of a community, a municipality might plan to build a new high-traffic road. On the other hand, the road might restrict children's access to school or to their favourite play areas. A plan such as this, while improving some aspects of emergency preparedness in a community, might also increase the risk of traffic accidents, thus endangering the lives of the children who live there.

4.2 Participatory community development

Participatory approaches to community development, including water and energy stewardship, environmental education, disaster risk reduction and preparedness, will create economic opportunity, reduce vulnerability and empower the most marginalized citizens to be contributors to and beneficiaries of a sustainable society.

The Tajikistan water quality project, briefly described in Section 1.3, and elaborated on in the box at right, illustrates how groups of well-organized children and school-based environmental projects can contribute to adaptation efforts and shows the importance of meaningful child participation in the face of climate change.

Older youth can be engaged in microenterprise and vocational opportunities that offer 'win-win-win' benefits for all. The first win is in providing economic opportunity for young people and sustainable development within their community. The second win is improvement of environmental conditions in the community, and the third is reduced vulnerability and risk to the impacts of climate change. The case study from Sierra Leone (page 22) was featured in the 2007 *UN World Youth Report*.

Strengthening basic public health infrastructure

Much of the health risk posed by climate change is preventable or can be treated through the scale-up of existing health programmes and interventions. The health concern that climate change poses is at

Water quality in Tajikistan

Providing clean water to schools is a big challenge in Tajikistan. Diarrhoea and typhoid are prevalent due to the lack of water supply, and children often drink still water from ditches. In order to improve the situation, it was important to have a full picture of the conditions and quality of water in schools and communities. This was not easy, since the problem is widespread, especially in rural areas.

A UNICEF-initiated school-based hygiene and sanitation project accomplished extensive, reliable water testing, led by children as researchers who sought to assess the quality of water at their schools and communities on a weekly basis. Volunteer children were given small test bottles containing special 'H₂S' strips that test for faecal bacterial contamination. Children collected water samples and kept them close to their body (to keep them warm) for 24 hours. A positive result turns the water in the test bottle black, and with a negative result the water remains clear.

The results were interesting and extremely useful. Within a short time, it was possible to generate a comprehensive map of hundreds of schools and communities where water quality was identified, an achievement that would have required considerable time and money if it were done through surveyors. Many communities were surprised by the results of the test where contamination was found even in the wells that had previously been assumed to be safe.

The child researchers became community hygiene promoters, raising awareness of the danger of drinking untreated water, introducing the practice of boiling contaminated water before use, and advocating for better sanitation facilities in and around water sources. The information was also coordinated with district health officials and became useful in making decisions on where the priorities were in bringing safe water and sanitary facilities to schools and communities.

Source: Goodman, D., Water, Sanitation and Hygiene Education... Children and adolescents leading the way in Tajikistan, Case Study, UNICEF New York/Tajikistan, 2005, available at <www.unicef.org/voy/media/Tajikistan.pdf>.

this stage not thought to be primarily a question of new diseases but the alteration of incidence, range, intensity and seasonality of many of the existing health disorders.⁸ Concerted action to strengthen key features of health systems and to promote sustainable and healthy development choices can enhance current health conditions as well as reduce vulnerability to future climate change.⁹

4.3 Environmental education

Preparedness for climate change is a strategy for empowering children, providing them with critical thinking skills and tools to address rapidly changing environments. Providing education in emergencies has been a powerful first response in terms of facilitating access to education for children affected by armed conflict and natural disasters. To this end,

FIGURE 4.1 - Adaptation and mitigation strategies for children

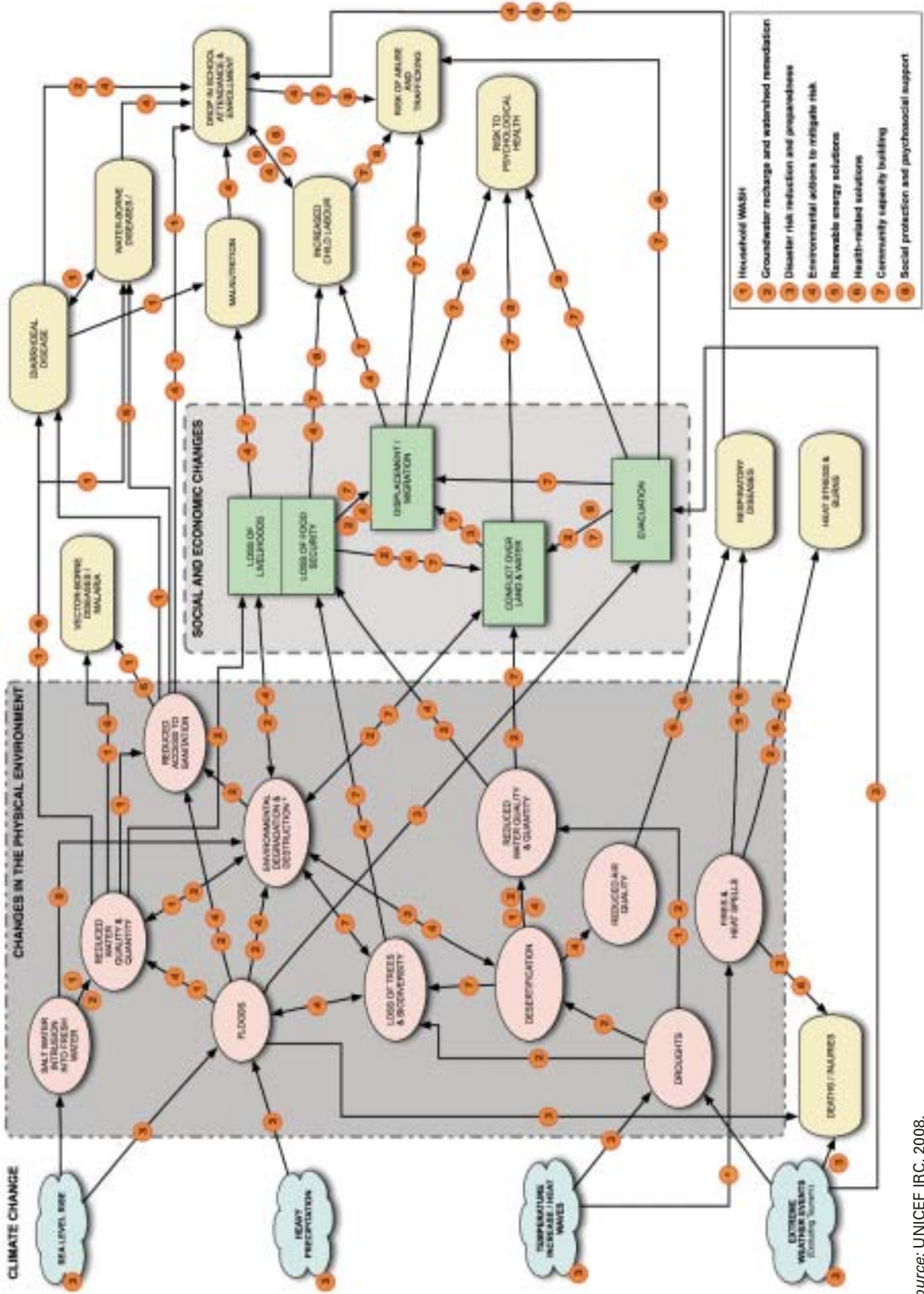

Note: This graphic model is intended to provide an overview of the complex pathways of climate change and their impacts on children. While the most critical linkages are shown, according to current knowledge, others – less significant or less direct – have been omitted with a view to readability.

Source: UNICEF IRC, 2008.

youth-led activities, such as community risk mapping, can go a long way to increase resilience at the community level. In educating children, several shifts are necessary. Chief among these is a shift from a prescriptive, expert-driven approach, to one of helping communities develop new solutions of their own and new social practices in support of common goals.

An interagency initiative is under way by UNICEF and partners to develop a gender-sensitive environmental education resource pack for use in child-friendly schools and spaces. The resource pack integrates solutions based on environmentally sustainable facilities (renewable energy, rainwater harvesting, ecological sanitation, gardens and reforestation) with a child-centred and rights-based participatory learning approach. It will offer stakeholders tools to analyse their situation, assessing the environmental threats to human security and offering both hardware and software solutions to address these challenges.

The pedagogical approach of the resource pack combines the participatory and skills-based approach of environmental and peace education, with the child-centred, rights-based and participatory methods set forth in the child-friendly schools framework. Thus, by giving support to the interrelated processes of improving children's environments in households, schools and microwatersheds, and developing children's capacity and promoting opportunities for participation, the resource pack aims to contribute to the twin goals of child survival and development and global environmental sustainability.¹⁰

Children and young people are the potential disaster management experts of the future, and can also teach disaster management within the family. It is therefore crucial to develop ways of involving families and communities in disaster education at school. Disaster education can contribute significantly to the ability of minorities to help themselves in time of disaster.¹¹

"Risk reduction can save lives and livelihoods, but in many cases it is still only an afterthought after major disasters," states Dr. Mukesh Kapila, policy director of the International Federation of Red Cross and Red Crescent Societies (IFRC). "This has to change, particularly as we know that climate change is already leading to an increase in the frequency and severity of extreme weather events that disproportionately affect poor and vulnerable people."¹²

Disaster risk reduction is being addressed both through development programming and emergency response, in a comprehensive approach that includes prevention, risk mitigation, preparedness, early warning, response and recovery. UNICEF is committed to introducing disaster risk reduction as part of its new cluster responsibilities in water, hygiene and sanitation, nutrition, protection and education, in close coordination with partners. One strategic UNICEF focus is formal and non-formal education, including school curricula, school safety

'Swim for Life' in Bangladesh

Drowning is the leading cause of death among children 1–17 years of age in Bangladesh. Each year, approximately 17,000 children in this age group die in this way. Of these deaths, 12,000 occur among children 1–4 years and the other 5,000 occur among the older age group, 5–17 years. Most of these deaths can be prevented through better supervision of the children. For children 5–17 years of age, teaching them to swim is a major preventive measure. UNICEF Bangladesh is supporting a local non-governmental organization, the Centre for Injury Prevention and Research, Bangladesh (CIPRB). Technical support to the project is provided by The Alliance for Safe Children (TASC) in three rural *upazilas* (subdistricts) in Bangladesh.

One of the important components is 'Swim for Life', developed with technical cooperation from the Bangladesh Swimming Federation and the Royal Life Saving Society of Australia. This programme is designed to provide life-saving swimming and water safety skills for children aged 4–10 years who cannot swim. The village ponds used and community swimming instructors were chosen in consultation with the village committees. The ponds are modified with a simple, feasible and sustainable technology as the materials used are locally available at a very low cost.

Source: Rahman, A. et al., 'Bangladesh Health and Injury Survey Report on Children', Ministry of Health and Family Welfare, Bangladesh, Institute of Child and Mother Health, Bangladesh, UNICEF Bangladesh and The Alliance for Safe Children, Bangkok, January 2005, <www.unicef.org/bangladesh/Bangladesh_Health_and_Injury_Survey-Report_on_Children.pdf>.

and public awareness. For example, in the Philippines, UNICEF works to make school buildings safer and to mainstream disaster risk reduction into school curricula. The strategy proposed by UNICEF emphasizes national-level capacity-building as well as community-based initiatives, since the first to respond to disasters are most often local populations, especially in disaster-prone remote areas.¹³

The World Summit on Sustainable Development in Johannesburg (2002) underpinned the need to integrate sustainable development into education systems at all levels to promote education as a key agent for change. Later, the UN General Assembly adopted the Decade of Education for Sustainable Development (UN DESD 2005–2014).

Education for sustainable development demands a reorientation away from a single focus on providing knowledge in a specific domain, towards a approach to dealing with interlinked problems and promoting the ability to take action in addressing complex issues. It focuses on helping people to better understand the world in which they live, and to better act on this understanding, addressing the complexity and interconnectedness of issues such as poverty, consumption, environmental degradation, health and population. In this respect, education for sustainable development shares many features, and could be used interchangeably, with life skills-based education.

Today's investment in 'environment-friendly' education and outreach with special attention to the needs of girls will lead to future generations of environmentally responsible citizens. So far, however, children's involvement in the domestic and international climate regime development process is sparse and sporadic.¹⁴

In order to be effective, life skills-based education planning must take into account the complex social settings in which children and adolescents live, many or all of which are impacted by climate change. Therefore, alignment of life skills education with adaptation, disaster preparedness and risk reduction related to climate change necessitates a process of learning that can assist children and young people to understand risks and opportunities, and empower them to become agents of positive action and change. This requires interventions that actively involve children and participants in planning, and that incorporate their knowledge, experience and concerns.

In February 2003, the Governing Council of the UN Environment Programme adopted a long-term strategy (Decision 22/18 II) for the engagement and involvement of young people in environmental issues. The word *tunza* means "to treat with care or affection" in Swahili, and the programme is built around this theme. It is an initiative that is intended to develop and implement activities in the areas of capacity-building, youth and environmental decision-making processes, environmental awareness and information exchange, seeking to foster a generation of environmentally conscious citizens, capable of positive action.

Instilling environmental awareness at a young age is the best way, ultimately, to protect the environment. Programmes that improve the availability and quality of environmental education are key interventions for long-term change. And while schools – and especially primary schools – are ideal platforms for increasing children's environmental knowledge, the most effective learning programmes go beyond schools and into communities.

Non-formal educational programmes empower those young people without access to formal learning systems to acquire the skills and knowledge to address environmental risks (including climate change) through local actions, as well as to increase gender equity, in relation to particular livelihood strategies in local communities. The process of learning about the environment can develop life skills that future generations can use to protect it, as well as equipping them with the skills, knowledge and perspectives to live in an ever-changing global environment.

4.4 Child and youth participation

All children have the right to participate in development programmes. Older children in particular have a capacity for participation that develops further as they mature. Partnerships with

children and young people in the Eastern and Southern Africa region have found that what children and young people know and do in relation to water, environment and sanitation is a resource that programme planners have yet to tap to any great extent.¹⁵ Moreover, this is the next generation of water users and environmental stewards at the household and community level. The capacity of these young people to live in harmony with nature and to manage and maintain local water, air and land resources effectively is absolutely vital to the sector.

TABLE 4.1
Possible adaptation activities involving children and young people

Activity	Location
Life skills-based intersectoral environmental education <ul style="list-style-type: none"> relating the child's local environment to her/his life in the context of the education curriculum, including science, mathematics, literacy and health community outreach activities led by youth clubs 	In schools and communities
Disaster risk reduction and preparedness <ul style="list-style-type: none"> risk mapping of communities led by youth clubs tree planting and erosion-control activities preparedness, evacuation 	In schools and communities
Vocational training in trades, i.e., forestry, masonry, health care to address environmental degradation and provide employment for youth <ul style="list-style-type: none"> to reach out-of-school youth to improve access to water to improve access to energy* 	In community centres, schools
Promotion of alternative energy for electrification of rural schools and health centres <ul style="list-style-type: none"> Working with the Global Environment Facility, the Clean Development Mechanism project, the Poverty and Environment Initiative and others 	In schools, health centres
Water source and microwatershed protection/remediation <ul style="list-style-type: none"> river clean-up campaigns monitoring and maintenance of water points fencing/hedging awareness-raising (contamination control measures) 	In schools, households, communities and microcatchments
Alternative water source development <ul style="list-style-type: none"> rooftop rainwater harvesting run-off collection (microdams, subsurface dams, pond construction) 	In schools, households and microcatchments
Alternative energy for water lifting <ul style="list-style-type: none"> solar pumping (where handpumps not appropriate) wind pumping (as above) 	Mainly in schools

* Framework for a Post-2012 Agreement on Climate Change: A proposal of the Global Leadership for Climate Action, 2007, p. 8, states: "Energy security and climate security are intertwined and should be addressed at the same time.... Renewable energy is a win-win proposition for all countries: (1) it provides opportunities for poverty alleviation and for satisfying the energy needs in rural and remote areas; (2) it helps generate employment and creates local economic opportunities; (3) it helps curb climate change and contributes to the protection of human health caused by air pollution".

4.5 The Nairobi Work Programme

The implementation and effectiveness of the UN Framework Convention on Climate Change (UNFCCC) process in addressing global climate change, especially in developing countries, is closely linked to its ability to simultaneously further development and poverty reduction goals. Capacity-building to support and facilitate these linkages will enhance the sensitivity of poverty reduction policies to climate issues.”¹⁶

The Nairobi Work Programme was initiated at the twelfth session of the Conference of the Parties to UNFCCC (COP 12) with the goal of helping countries improve their understanding of climate change impacts and vulnerability and to increase their ability to make informed decisions on how to adapt successfully. It is an international framework implemented by Parties, intergovernmental and non-governmental organizations, the private sector, communities and other stakeholders.

There are nine areas of work, all of them important to increasing the ability of countries to adapt. They address the overall objectives of the Work Programme and are consistent with the nine action-oriented sub-themes of Decision 2/CP.11.¹⁷

1. Methods and tools
2. Data and observations
3. Climate modelling, scenarios and downscaling
4. Climate-related risks and extreme events
5. Socio-economic information
6. Adaptation planning and practices
7. Research
8. Technologies for adaptation
9. Economic diversification

In at least four out of these nine areas, influence can be exerted to include children in the development of responses.

- **Methods and tools** used for impact, vulnerability and adaptation assessment: These encompass a broad range of applications – cross-cutting or multidisciplinary (e.g., climate models, scenario-building methods, stakeholder analysis, decision-making tools).

An effort to define and integrate indicators to monitor and evaluate efforts within education and health sectors to engage and to serve the most marginalized children into emerging government plans would strengthen future reporting mechanisms and help substantiate and scale up sustainable activities.

- **Climate-related risks and extreme events:** UNFCCC acknowledges that a strong body of experience in dealing with climate-related risks already exists in the disaster risk reduction community, but also points to continuing gaps in knowledge. In an effort to close these gaps, activities in this area of work are undertaken with the objective of promoting understanding of the impacts of, and vulnerability to, climate change, current and future climate variability and extreme events, and the implications for sustainable development.

Environmental education both in and out of school, which includes community mapping to indicate needed actions to mitigate risk (for example, planting forests to sequester carbon can also stabilize soils and avoid floods; rural electrification of homes and schools can support sustainable development), as well disaster risk reduction and preparedness activities, can substantially reduce risk. Preparedness for climate change can be seen as a strategy for empowering children, providing them with the means to bolster their structurally vulnerable status. Turning ‘education-about-emergency’ into a means of empowerment is the real challenge.

UNICEF has achieved its best results in preparedness by integration of planning, training and drills/simulations. Not one of these alone is enough, but the combination of all three seems to have a synergistic effect in terms of building up capacity to respond in an effective and timely manner during emergencies.

- **Socio-economic information:** For communities all over the world, socio-economic and natural conditions are changing over time, in some cases quite dramatically. As a result, vulnerability to climate change and the effectiveness of adaptation are also being affected. The shifts in the socio-economic structure of societies continue to pose risks and challenges to a significant number of people.
- **Adaptation planning and practices:** A government, regional authority or community must plan and decide on the best ways to reduce its vulnerability to those impacts, and on how these can be implemented in the most effective manner.

4.6. Frameworks for action

National Adaptation Programmes of Action

A number of countries, including the least developed countries, have drawn up adaptation plans or are in the process of finalizing them. National Adaptation Programmes of Action (NAPAs) provide a way to identify priority activities that respond to countries’ immediate needs and concerns for adaptation to climate change. They build on existing coping strategies at the grass-roots level and promote the use of relevant traditional knowledge and practice.

Given that NAPAs look at priority areas, it is instructive to examine how they refer to children. In the case of Sudan, the entire NAPA document refers only once to children, in the context of their vulnerability to malaria. Annex A presents a case study that reveals the vulnerabilities of children in southern Sudan under climate change.

As adaptation efforts are positioned to receive more emphasis and funding, it is increasingly important to pursue appropriate forms of adaptation and ensure that money is spent in the right way. To organize adaptation through top-down

programmes will alienate local communities likely to resist what they will perceive as external impositions, decided by government authorities from which they feel distant and by outside experts far from the local conditions.¹⁸ Therefore, effective adaptation in developing countries will require broader planning capacity in all relevant departments and ministries to gain the trust of district- and municipal-level functionaries.

Hyogo Framework for Action 2005–2015

With the Hyogo Framework for Action 2005–2015, adopted in January 2005, 168 Governments agreed on a 10-year plan to make the world safer from natural hazards at the World Conference on Disaster Reduction held in Hyogo, Japan. The Hyogo Framework is a global blueprint for disaster risk reduction efforts during the period 2005–2015. It is based on the premise that disasters affect everyone and are therefore everyone's business. Disaster risk reduction should be a part of everyday decision-making: from how people educate their children to how they plan their cities. Each decision can make us either more vulnerable or more resilient.¹⁹

Cooperation is crucial to disaster risk reduction: States, regional organizations and institutions, and international organizations all have a role to play. Civil society, including volunteers and community-based organizations (including schools and youth organizations), the scientific community, the media and the private sector are all vital stakeholders. The International Strategy for Disaster Reduction (ISDR) is the secretariat, accountable to the UN Secretary-General, and serves as broker, catalyst and focal point for disaster risk reduction within the UN and among the members of the ISDR system. It advocates for commitment to disaster risk reduction and implementation of the Hyogo Framework, and reports on progress.

The goal of the Hyogo Framework is to substantially reduce disaster losses by 2015 – in lives, and in the social, economic and environmental assets of communities and countries. The framework offers guiding principles, priorities for action and practical means for achieving disaster resilience for vulnerable communities.

The Hyogo Framework for Action priorities are to:²⁰

- Ensure that disaster risk reduction is a national and local priority with a strong institutional basis for implementation
- Identify, assess and monitor disaster risks and enhance early warning
- Use knowledge, innovation and education to build a culture of safety and resilience at all levels
- Reduce the underlying risk factors
- Strengthen disaster preparedness for an effective response at all levels.

At the international level, institutional linkages are forming to coordinate policies and measures within the respective political frameworks, i.e. the UNFCCC

and the Hyogo Framework for Action, the latter containing specific reference to climate change. Currently, some efforts are being made by development partners to encourage integration of disaster risk reduction into frameworks such as poverty reduction strategies and the common country assessments of the United Nations Development Assistance Framework.

Roll Back Malaria

The UN General Assembly adopted Resolution 61/228 entitled '2001–2010: Decade to Roll Back Malaria in Developing Countries, Particularly in Africa' on 22 December 2006, which called on malaria-endemic countries to encourage regional and intersectoral collaboration, both public and private, at all levels, especially in education, agriculture, economic development and the environment to advance malaria control objectives. It further urged Member States, the international community and all relevant actors, including the private sector, to promote the coordinated implementation and enhanced quality of malaria-related activities.

Subnational and municipal frameworks

A meaningful channel of communication between the generations is beneficial to everyone and helps ensure that even those normally at risk in our communities are not neglected. Participation is an essential part of development, for development is "the process by which communities, families and individuals grow stronger, can enjoy fuller and more productive lives and become less vulnerable."²¹ A community may be considered developed if it ensures that all its members, whatever their age, are involved in trying to shape lives of dignity for all.

In recent years the value of the Child-Friendly Cities Initiative has been recognized by a large number of municipalities. Not only have many municipalities initiated such projects, but also the initiative is being supported by national or regional mechanisms to promote the realization of child rights. In this context, many cities carry out internal and external assessments of their participatory structures and activities to understand the fulfilment of the rights of children. At the present time, however, issues related to climate change, the vulnerability of children to its effects, and assessments of risk for children are not integrated into the agenda of most of these initiatives. This is a missed opportunity, since they present a great potential for involving communities – and especially children and youth – in climate-related research, environmental education and various community-based adaptation projects. Strengthening the links between climate change concerns and child-friendly initiatives will lead to the strengthening of local capacity in terms of adaptation and preparedness.

Local adaptation strategies and local action

In order for adaptation strategies to work, they must lead to change at the local level. A key indicator of successful adaptation at local level is an increase in

the coping capabilities of families. The following table shows examples of participatory adaptation strategies, which involve and engage young people while reducing risk to children.

Local communities and municipalities unfortunately face great challenges in the development of their adaptation plans. The municipalities and localities most at risk are also frequently the poorest ones. Poor people in these communities are often barely surviving and are hardly in a position to implement comprehensive adaptation plans. It should be noted, however, that these people are also quite resourceful when it comes to responding to

disasters and extreme climatic events. It would be a big mistake to label them simply as 'victims'. Primarily, they are 'survivors' who manage to hold on and raise their families in very challenging conditions, both economically and environmentally. The strength and creativity of these communities is a major asset for the development and implementation of local, community-based adaptation plans. A wide range of illustrations of this quality may be identified; one example of local adaptation, in the context of a school feeding programme in Kenya, is described in annex D (page 44).

TABLE 4.2
Possible adaptation activities involving children and young people

Adaptation strategy	Examples
Reducing vulnerability and increasing local capacity	<ul style="list-style-type: none"> • Conducting vulnerability assessment studies at the local level • Intergenerational dialogue and training on youth-led community mapping of risks and disaster preparedness • Small-scale entrepreneurship projects • Vocational training for out-of-school youth and women, related to renewable energy technologies, rainwater catchment, groundwater recharge, small-scale irrigation, environmental clean-up/reparation • Increased vector control and response to waterborne diseases • School gardening programmes initiated to support nutrition
Improving infrastructures	<ul style="list-style-type: none"> • Strengthening early-warning systems (including school-based weather monitoring) • Improving local water and sanitation systems • Community projects such as canal excavation, reducing waterlogging, raising of embankments
Increasing awareness	<ul style="list-style-type: none"> • Creation and dissemination of newsletters and publications • Environmental education projects • Awareness campaigns on climate change
Strengthening organizational cooperation	<ul style="list-style-type: none"> • Better information exchange between governments, international governmental organizations and non-governmental organizations. • Building civil society alliances • Initiating discussions on the Convention on the Rights of the Child and climate change at all levels

NOTES

- 1 Stern, N. (ed.), *The Economics of Climate Change: The Stern Review*, 2006.
- 2 Stern, N. (ed.) *The Economics of Climate Change: The Stern Review*, 2007; UNDP, UNEP, World Bank, ADB, AfDB, GTZ, DFID, OECD, European Commission, Netherlands Development Cooperation, *Poverty and Climate Change: Reducing vulnerability of the poor through adaptation*, launched at the eighteenth session of the Subsidiary Bodies of the UNFCCC in Bonn, Germany, 10 June 2003.
- 3 Ibid.
- 4 Hutton, G. and L. Haller, 'Evaluation of the costs and benefits of water and sanitation improvements at the global level', WHO, 2004.
- 5 Ibid.
- 6 Ibid.
- 7 Global Leadership for Climate Action, *A Proposal Framework for a Post-2012 Agreement on Climate Change*, 2007, p. 13.
- 8 McMichael, A.J. et al., Global Environmental Change and Health: Impacts, inequalities, and the health sector, *British Medical Journal*, vol. 226, pp. 191-194 .
- 9 <www.who.int/globalchange/climate/en/>, accessed 7 March 2008.
- 10 See <www.ungei.org/resources/files/EERP_modular_contents_web.pdf>, accessed 3 November 2008.
- 11 IFRC, *World Disasters Report 2007, Focus on Discrimination*, Kumarian Press Inc., Bloomfield CT/Eurospan, London for IFRC, 2007, pp. 53-59.
- 12 IFRC, Risk reduction conference must result in meaningful action "on the ground", 5 June 2007, <www.ifrc.org/Docs/News/pr07/3007.asp>.
- 13 *UNICEF Humanitarian Action Report*, 2008, p. 9.
- 14 Cando, Lee, 'UNICEF and Climate Change', Youth Discussion Paper, January 2008.
- 15 UNICEF Eastern and Southern Africa Regional Meeting on Child Participation in WES Final Report, Nairobi, October 2006.
- 16 UNDP, UNEP, World Bank, ADB, AfDB, GTZ, DFID, OECD, European Commission, Netherlands Development Cooperation, *Poverty and Climate Change: Reducing vulnerability of the poor through Adaptation*, 2003, pp. 31-32.
- 17 Nairobi Work Programme, <http://unfccc.int/adaptation/sbsta_agenda_item_adaptation/items/3633.php>.
- 18 Smith, Dan and Janani Vivekananda, A Climate of Conflict: The links between climate change, peace and war, International Alert, November. 2007, p. 4.
- 19 ISDR, Hyogo Framework for Action 2005-2015, <www.unisdr.org/hfa>.
- 20 Ibid.
- 21 IFRC, *Strategy 2010: To improve the lives of vulnerable people by mobilizing the power of humanity*, IFRC, Geneva, 1999.

5

IMPLICATIONS AND CONCLUSIONS FOR POLICY AND PRACTICE

The evidence presented in this review confirms the centrality of children to the discussion of climate change and to any reflection on its human security implications. But children's issues are not yet well recognized or incorporated – thus a major message of this report as well as of others now being generated is that these issues urgently need to be brought to all efforts to address climate change and its human security aspects.

While children are among the most vulnerable to climate change, it is equally notable that they can be key agents for social change, economic development and technological innovation. Empowered children are dynamic and ultimately powerful protagonists for protecting and improving the environment.¹ Instilling environmental awareness at a young age is the best means, looking to the future, to protect the environment.

Children can and should be partners in understanding and acting on the issue of climate change. They are more likely to be able to learn to utilize environmental resources in fundamentally new ways. They have an inherent curiosity about the environment and struggle to understand their place in the world from an early age. In educational and public informational programmes they are commonly encouraged to carry out small, local actions to help with environmental problems.

The changing global environment has evolved to become very complex and calls for integrated and sustainable approaches. Lack of access to clean household energy, water, sanitation and education, compounded by the increasing prevalence and severity of natural disasters, are often simultaneous, resulting in perilous effects with significant impact on family household security and the lives of children.² Likewise, 'low-tech' adaptation interventions can substantially reduce risk and increase the resilience of local communities.

Climate change is inextricably linked to the broader sustainable development agenda for children,

including the challenge of poverty reduction and efforts to meet the MDGs. Poverty reduction strategies should be used to conduct national estimates of the cost of scaling up existing programmes (in diverse sectors including education, youth, water, health and environment), identifying priority areas for reducing vulnerability.

It is vital to support children and young people towards inquiry- and skills-based learning to enable critical thinking as well as give them access to resources to understand their local environment, to map and eradicate risks and to live in harmony with nature. This can and should be a key part of meaningful strategies to build resilience to climate change in countries and communities. Experience demonstrates the potential of children to act as part of the solution, to play a leading role within all of society to act on climate change concerns.

Priority efforts are required to identify and understand the remaining knowledge gaps regarding climate change and children and create pathways of communication and action on this subject by a wide range of partners, as a critical action to ensure the safeguarding of children's rights in the context of climate change. This, in turn, will help further consolidate our human security efforts.

For example, the lack of accurate age-specific data on children fosters confusion and disparity among policymakers and planners at national and international levels. The tendency to group all children into a single category omits critically important factors relevant to different ages, especially information related to adolescents, which is almost completely missing in current data.

Much of the health risk posed by climate change is preventable or curable through the scale-up of existing health programmes and interventions. The health concern that climate change poses is at this stage not thought to be primarily a question of new diseases; instead, climate change will alter the

incidence, range, intensity, or seasonality of many of the existing health disorders. Concerted action to strengthen key features of health systems and to promote sustainable and healthy development choices can enhance current health conditions as well as reduce vulnerability to future climate change.³

The key conclusions emerging from this paper are the following:

- **A human rights-based approach necessitates inclusion of children's issues** within all international and national efforts to address climate change and its human security aspects. States Parties to the Convention on the Rights of the Child can be urged to integrate practical multisectoral considerations that bring climate change and environmental degradation into sector-wide approaches and poverty reduction strategies.
- **All possible opportunities should be taken to integrate the children's agenda into relevant intergovernmental processes.** Examples among many include the UN General Assembly high-level thematic debate on climate change, the United Nations Economic and Social Council (ECOSOC) event held in April 2008 on 'Achieving the MDGs and Coping with the Challenges of Climate Change: A review of commitments and actions by ECOSOC'. It is critical to make efforts to bring the children's agenda forward in these and other intergovernmental events related to climate change.
- **National Adaptation Programmes of Action (NAPAs) and other regional and municipal adaptation plans should incorporate a children's dimension.** Specifically, it is important that NAPAs and other plans be coordinated with ministries such as education, health and youth, as well as give special attention to the needs and vulnerabilities of children of different ages.⁴ It is crucial for stakeholders to support governments and encourage municipalities and communities to raise awareness and build capacity among children to address disaster risk reduction, community risk mapping, and preparedness. Successful integration of planning, training and drills or simulations that ensure that children and their concerns are taken into account within the child-friendly schools and child-friendly cities frameworks would yield meaningful results within existing programme structures in cities and countries.
- **Many opportunities exist for the international community to generate support for community empowerment, shared learning between countries and communities and field activities designed for results.** Climate change is an issue that connects us all. The world's water cycle is a closed system; rivers and aquifers flow between countries; we all breathe the same air; and greenhouse gas emissions and ozone depletion are wide-reaching. A platform for shared learning of best practices and lessons

learned specific to issues related to intergenerational implications and to the needs and capacities of children can add value to all stakeholders. This might be set up, for example, as an additional portal to the UNFCCC information clearing house, CC:iNet.⁵

- **Support is needed for improved energy efficiency and conservation and increased access to clean household energy.** This includes promotion of water-saving technologies focused on community management of local water resources, including rainwater harvesting (for use by households and schools and groundwater recharge), microwatershed management and operational research. There are opportunities in renewable energy solutions for schools and health centres in rural communities off the grid, and support for vocational training and microenterprise opportunities in the energy sector for young people.
- **Partnerships are key.** United Nations organizations, donors, governments and civil society can work in cooperation and collaboration to reduce and mitigate risk through environmental education and social and behavioural change. A working example of this is an emerging project under the auspices of article 6 on education and outreach of the UN Convention on Climate Change. This brings together TERI (The Energy and Resources Institute), UNFCCC, UNICEF, the UN Inter-Agency Committee for the Decade of Education for Sustainable Development, government counterparts and other stakeholders.
- **There is urgent need for donor support for the local actions of children and young people.** Funds directed to operational research projects in developing countries that are designed with baseline indicators and monitoring guidelines will serve the dual purpose of substantiating anecdotal assumptions regarding the capacities of children under article 12 of the Convention on the Rights of the Child, while providing practical support to youth-led activities and increasing community resilience overall.
- Although it is not the subject of this paper, **investment in infrastructure is essential.** The likelihood of sustainable success is increased when infrastructure investment is coordinated in consultation with children and/or developed with the needs and capacities of children in mind.
- **Further approaches to research on climate change and children should be explored.** It is vital to understand the importance of the potential role of longitudinal studies, the identification of economic and social indicators and trends, and opportunities to contribute scientific data to future IPCC and other intergovernmental reports. Key questions include: how to bring data specific to vulnerabilities of children and their local environments into studies and reports; how to

substantiate the effectiveness of local actions of children (including environmental action, and disaster preparedness and response); and how to bring children's perspectives and voices into debates and reports.

Through these and other actions, it will be possible to further promote the identity and contribution of children and young people to the global challenge posed by climate change and thus contribute to the cause of human security on a long-term basis.

NOTES

- 1 UNICEF, *Climate Change and Children*, 2007.
- 2 The Gleneagles Communiqué: "We face serious and linked challenges in tackling climate change... (d) Reducing pollution protects public health and ecosystems. This is particularly true in the developing world. There is a need to improve air and water quality in order to alleviate suffering from respiratory disease, reduce public health costs and prolong lives"; <www.number10.gov.uk/Page7881> accessed 27 October 2008.
- 3 'Climate Change and Human Health', <www.who.int/globalchange/climate/en/>, accessed 7 March 2008.
- 4 For example, the National Programme of Action for Climate Change prepared by Sudan does not mention children.
- 5 Climate Change Information Network, <http://unfccc.int/cc_inet/items/3514.php>.

ANNEX A

CASE STUDY: SOUTHERN SUDAN

Background information

Sudan covers 2,505,810 sq. kms and is the largest country on the African continent.¹ An arid desert climate in the north changes to a tropical climate in the south. The country has a very fragile ecosystem. Frequent droughts, flooding, soil erosion and desertification are already affecting most of the land, making it extremely vulnerable to climate changes.

The civil wars (1955–1972 and 1983–2005) took a big toll on human life, and caused social and economic instability. It is estimated that 2 million people died and 6 million people were displaced, and most of the infrastructure in Southern Sudan has either been destroyed or largely damaged. Only after the signing of the Comprehensive Peace Agreement in 2005 did things start to return to normal in the south, where about 10 million people live.²

The population in the south is very young, with a population mean of 16. The average household size is six, and, as a result of the long-lasting armed conflict, a significant 13 per cent of households are headed by women.³

Health care is insufficient to address need. There is only 1 doctor for every 11,000 people, of whom 95 per cent are living in urban centres. In rural areas, only 10 per cent of the population has access to safe water. Although declining, the overall infant mortality rate is 40 per 1,000 live births. The mortality rate for children under five is 135 per 1,000 live births.⁴ Levels of wasting among children in Southern Sudan are very high, with annual rates ranging from 15 per cent to 30 per cent. Childhood undernutrition peaks at certain seasons of the year, especially during the malarial season.

To earn a living, 75 per cent of the households in Southern Sudan rely on agriculture and pastoralism.⁵ Only 3–4 per cent of the families have employed work and the same percentages rely exclusively on food aid.⁶

Vulnerability to climate change

The findings of the first vulnerability assessment give cause for concern for Sudan's human security in the face of the changing climate. The three sectoral assessments suggest that, even with modest changes in climate, Sudan faces significant threats in terms of food security, export crop production, human health and water availability.⁷

Climate scenario analyses conducted for Sudan's First National Communication indicated that the average temperatures are likely to increase significantly above national baseline numbers by 2060. The projected warming ranges are from 1.5° C to 3.1° C for the month of August and 1.1° C and 2.1° C for the month of January.⁸ The same models also show that the average rainfall during the rainy season is likely to drop 6mm/month.

Drought is one of the most serious natural phenomena faced by Southern Sudan. Worsening droughts are forcing inhabitants to expand their geographic range at the expense of the environment. Rain-fed cultivation, together with animal husbandry, has resulted in the expansion of farming areas and grazing lands. Combined with firewood collection, this economic pattern has caused the desertification of vast areas, endangering the future food security of everyone, including children.⁹

Effects of climate change on children

The overall impacts of climate change on children are rarely direct. A changing climate leads to changes in the availability, quality and uses of land and water, which in turn produce negative effects on a number of measures of health and quality of life.

In Southern Sudan, unlike the rest of the country, families generally adopt a subsistence lifestyle where they grow most of their own food and supplement it by hunting and fishing. Households most at risk for food security tend to be more reliant on agriculture, hunting and fishing, and food aid.

Droughts and land degradation are causing serious drops in food production. It is estimated that in the coming 30 years, sorghum production (a staple food for most children in the country) is expected to decline more than 50 per cent.¹⁰ Unless effective adaptation strategies are implemented, this would mean widespread undernutrition and death for huge numbers of children. Female-headed families are at an even higher risk. Children who were just returning to school after the peace agreement of 2005 could be pulled out again for economic reasons or because their families may relocate in pursuit of water resources.

In Southern Sudan, school-aged children are responsible for looking after the cattle. Cattle farms may be located 20 to 50 km away from their homes, near a water source. The children spend all of the dry season in these areas, away from home and friends and missing school. As the drought intensifies due to climate change and the dry season gets longer, children will be spending more and more time away from home in order to help their families survive. And household work is not the only issue of concern. As food sources and livelihoods diminish, more children are left to fend for themselves all day or to find work in exploitative situations.¹¹

Research in Southern Sudan identified how undernutrition is not just a question of the amount of food available. It relates to other key environmental factors closely connected to climate change. An examination of the seasonal patterns in undernutrition rates showed that the highest levels of undernutrition among children were seen at the end of the dry season or the beginning of the rainy season. During these periods, food supplies become strained, cattle are away from the homestead, meningitis outbreaks are common, households are forced to rely on the less safe sources of drinking water, and vector-borne and infectious diseases are more prevalent. For example, research findings show that “the incidence of stunting was 21 per cent lower among children from homes with both water and sanitation as compared to those lacking these facilities”, illustrating that improved child growth is not only a food security issue but is closely related to water and sanitation.¹² As the access to clean water in Southern Sudan deteriorates as a result of climate change, we can expect further increases in stunting among children.

There is also a close link between nutrition and school attendance. Most children eat one meal per day, which provides insufficient nutrition for their age. During workshops conducted in the village of Rumbek, schoolteachers observed that children who are continuously hungry are unable to follow the lessons, concentrate or participate in the classroom activities.¹³

Diarrhoea is common among children in Southern Sudan. A survey indicated that 43 per cent of children overall experienced an episode of diarrhoea in the two weeks preceding the survey. Studies showed that scarcity of water rather than bacterial contamination was the cause of the alarmingly high prevalence of diarrhoeal, skin and eye communicable diseases (water-washed diseases) among children and adults.¹⁴

Southern Sudan is located in the most highly endemic zones of malaria in Africa. Fingers of the Upper Nile regularly flood in the southern part of the country, making it an ideal place for mosquitoes to breed and malaria to flourish. There are no reliable data, especially on malaria-related child mortality in Southern Sudan.¹⁵ It is calculated that children in Sudan will be exposed to a significantly increased risk of malaria under climate change.¹⁶

Another study examining acute respiratory infections found that 38 per cent of children reported a cough in the two weeks preceding the survey, and one quarter of the children had difficulty breathing during these episodes.¹⁷ A multiple indicator cluster survey conducted in Southern Sudan reported similar results (30–45 per cent) for children under five.¹⁸ The relationship between droughts, air quality and respiratory diseases is well established, and it is very likely that as the climate becomes less hospitable in Southern Sudan, the rates of acute respiratory infections among children will increase in the absence of health interventions.

The last alternative for families that cannot survive is to migrate. Migration in such circumstances has devastating effects on children. In recent years, families hit by the effects of desertification in Darfur and the central and northern regions migrated to the south, and are now facing hunger, unemployment, insecurity and famine.

Climate change tips the fragile balance of nature in Southern Sudan in such a way that each of the numerous threats to human security builds upon another.

Adaptation strategies

Sudan realized the potentially destructive effects of climate change quite early. In 1993, Sudan ratified the UN Framework Convention on Climate Change (UNFCCC). In 2003, it submitted its Initial National Communication with the assistance of the United Nations Development Programme. Sudan’s National Adaptation Programme of Action (NAPA) was issued in 2007 and built on the work of project teams that acted at national as well as regional levels. This was the first time it was possible to extend the climate change activities to the south, due to the signing of the Comprehensive Peace Agreement. Sudan is currently preparing its Second National Communication, covering the years 2007–2009.

The priority project selected for Southern Sudan in its NAPA is entitled ‘Strategies to adapt to drought-induced water shortages in highly vulnerable areas in Central Equatorial State’. The main goal of the proposed project is to promote sustainable livelihoods. An expected

outcome of this project is that it will prevent children from travelling with cattle and spending long months in cattle camps away from school. A second expected outcome is the reduction in waterborne diseases that threaten the health of most children. The distances covered by young girls to fetch water are also expected to be shortened, improving productivity. Finally, by increasing crop and milk production and by introducing new natural food resources such as fish and fruit trees, it would be possible to combat the chronic undernutrition that affects children.

Local adaptation projects

The most successful local adaptation projects to combat the impacts of drought in Sudan are those that prioritize sustainable livelihoods. Most of these projects are initiated by non-governmental organizations and other organizations working in Sudan. In a number of case studies conducted in rural Sudanese communities, evaluated projects included small-scale irrigated vegetable gardens, pest management, improvement of water supply through the construction and management of water wells, forestry/rangeland rehabilitation, windbreak, sand dune stabilization, and tree and shrub planting. The level of participation from women and marginalized groups was excellent. While the studies did not look at the impacts of the projects on children separately, the expanded livelihood options for the families can be considered very important for the well-being of their children. Additionally, the greater participation of women in the income-generating activities gave them a sense of independence that led to new activities specifically for women, such as motherhood care and access to better child schooling opportunities.¹⁹

The capacity of local farmers to changing conditions should not be underestimated. In El Fasher, Sudan, residents have adapted to drought by building low earth embankments Africans call *trus* around their villages to hold water and irrigate crops of sorghum and vegetables. In eMcitsheni, a rural area reachable only by dirt road and whose households are dependent on agriculture and livestock, several adaptation strategies include planting crops further apart so more moisture is available for each row.²⁰

There is no evidence that child or youth participation is an important – or integral – part of these projects. There is also very little information on how schools can be involved in awareness raising, environmental education and community-based adaptation projects. Some very small-scale experiments such as building school gardens to supplement the daily diet of the schoolchildren have been undertaken, but remain an exception.²¹

Cost of adaptation

Despite many ongoing efforts, Sudan does not have the resources and capacity to absorb necessary costs of adaptation. It is estimated that by 2039, developing countries will need US\$28 billion to \$67 billion in funds in order to adapt to climate change. This corresponds to 0.2 to 0.8 per cent of global investment flows. Current investment in adaptation is just a fraction of this amount.

In Africa rural farmers have been practising a range of agricultural techniques as coping strategies and tactics to enable sustainable food production and deal with extreme events. These include intercropping and crop diversification, use of home gardens, and diversification of incomes and herds, such as the introduction of sheep in place of goats. For example, in the Bara Province in Sudan, the shift to small-scale irrigated vegetable gardens and efforts to stabilize sand dunes have helped raise food output.

Child and youth involvement in these local projects is rarely found in Sudan, as in many other countries. This is a missed opportunity, since it is demonstrated that children and youth frequently possess the knowledge and capacity to participate together with adults in projects that impact on their lives.²²

Conclusions

Southern Sudan is a dramatic example of a region where a very fragile socio-economic system is being threatened by changes in the climate. Statistics show that children in this area are extremely vulnerable, with climate change acting like a “threat multiplier”²³ in that it exacerbates pre-existing risks to human health and welfare. One major issue is the very low adaptive capacity of the families. For example, providing alternative food security options to farmers who mainly rely on rain-fed farming and pastoralism is a major challenge.

A comprehensive analysis of ongoing internationally funded projects in Sudan clearly indicates the big gap between child-centred projects and climate change projects.²⁴ For example, the work plan for Sudan lists 14 separate projects ranging from education on the Convention on the Rights of the Child to child-friendly schools, yet none of the programmes cover issues related to climate change. Consequently, projects that deal with

climate change do exclude children and youth, while mainly targeting or involving adults. This is surprising, since one would expect that raising awareness about climate change among children should have been a priority for a country like Sudan.

A better focus on the needs and rights of children with respect to climate change can help to establish links between adaptation planning and children. For example, Sudan's NAPA document mentions children only once. While it is clear that children are likely to benefit from all of the proposed adaptation projects to some degree, it is important to have some studies that assess the degree of these impacts on children.

Giving priority to local adaptation efforts in countries like Sudan will be less costly, and more beneficial. While local capacity-building and empowering women are important priorities for Sudan, involving children and youth in adaptation planning and implementation does not seem to be on the agenda. This might be related to extreme sensitivity towards children who have suffered a great deal and who already have hard lives. On the other hand, research shows that it is important for children to participate in the affairs of their community in a meaningful way and to have their voices heard.²⁵ Article 12 of the Convention on the Rights of the Child has established this right. By involving children in local, climate change adaptation projects, Sudan will only strengthen its course in making life better for all its citizens.

NOTES

- 1 This case study primarily focuses on the southern part of Sudan. Southern Sudan, for purposes of discussion in this report, is comprised of the 10 southern-most states in Sudan. South Sudan refers to the following states: Northern Bahr El Ghazal, Western Bahr El Ghazal, Warrup, Lakes, Unity, Upper Nile, Jonglei, Western Equatoria, Central Equatoria and Eastern Equatoria. While the climatic, social and economic differences are significant between the north and the south of the country, it is often impossible to find statistical data that are only applicable to southern Sudan. In those cases, countrywide data were used instead.
- 2 'Sudan: Southern Sudan province, comprehensive food security and vulnerability analysis (CFSVA)', prepared by Jonathan Rivers et al., Dec. 2007.
- 3 Data from 'Sudan Household Health Survey', 2006.
- 4 Sudan's First National Communication under UNFCCC, vol. 1, 2003.
- 5 Pastoralism or pastoral farming is the branch of agriculture concerned with the raising of livestock. It is animal husbandry: the care, tending and use of animals such as goats, cattle and sheep. It may have a mobile aspect, moving the herds in search of fresh pasture and water.
- 6 Data from 'Sudan Household Health Survey', 2006.
- 7 Sudan's First National Communication, vol. 1, 2003.
- 8 There were no separate scenarios developed for Southern Sudan. The numbers reported here reflect the outputs of global circulation models applied to the central part of Sudan.
- 9 'Enabling Activities for the Preparation of Sudan's Second National Communication to the UNFCCC', UNDP, 2007.
- 10 Sudan's First National Communication.
- 11 El-nagar, S. E., 'The Impact of War on Women and Children: Case study of Sudan'. 1992, *Women*, vol. 5, 2000, pp. 9-11.
- 12 Merchant, A. T., 'Water and sanitation associated with improved child growth', *European Journal of Clinical Nutrition*, vol. 57, 2003, pp. 1562-1568.
- 13 Iltus, S., 'Community Participation for Understanding and Improving the Physical Environment of Schools for Children', Report submitted to Save the Children Sweden, 2007.
- 14 Awad, E. L. et al., 'Social and public health implication of water supply in arid zones in the Sudan', *Social Science & Medicine*, vol. 20, no. 4, 1982, pp. 393-398.
- 15 'Malaria at a crossroads' IRIN, January 2006, <www.irinnews.org/Report.aspx?ReportId=57920>.
- 16 UNDP, Project of the Government of Sudan, 'The Preparation of a National Programme of Action (NAPA)', 2003.
- 17 'Sudan Household Health Survey', 2006.
- 18 'Towards a Baseline: Best estimates of social indicators in Southern Sudan', UNICEF, 2004.
- 19 Osman-Elasha, B. et. al., 'Adaptation Strategies to Increase Human Resilience Against Climate Variability and Change: Lessons from the arid regions of Sudan', Assessments of Impacts and Adaptations to Climate Change Working Paper No. 42, October. 2006.
- 20 Giles, J., 'Climate Change 2007: How to survive a warming world', *Nature*, vol. 446, no. 4, Apr. 2007, pp. 716-717.
- 21 Iltus, S., op. cit.
- 22 Hart, Roger A., *Children's Participation: The theory and practice of involving young citizens in community development and environmental care*, Earthscan, London, 1997.
- 23 Quoted in 'Global warming may heat up conflicts, too', <www.csmonitor.com/2007/1206/p13s02-wogi.html>, 6 December 2007.
- 24 2007 Work Plan for Sudan: Projects by agency and sector, National Programmes, <http://workplan.unsudanig.org/2008/docs/WP08_NP_supporting_projects_by_org.pdf>.
- 25 Hart, Roger A., *Children's Participation*, op. cit.

ANNEX B

CASE STUDY: MOROCCO

Background

Morocco, located between the Atlantic Ocean to the west and the Mediterranean Sea to the north-east, has a very diverse topography. The country has a 3,400 km-long coastline that significantly influences its climate. The Atlas mountain range rises more than 4,000 metres, and the Sahara Desert is to the south of the country. In the northern heights of the country, average rainfall is more than 2 metres per year, yet the dry Saharan zone receives less than 25mm of rain.

In the past decades, Morocco suffered a number of extreme droughts that shook its political stability. Cereal production was sharply reduced, food security was threatened and in both 1981 and 1984, violent rioting erupted due to increased prices of the basic food staples that supply nearly 90 per cent of the calories in the average Moroccan diet.¹

Morocco is experiencing rapid population growth. Since the turn of the century, total population increased sixfold, from 5 million to today's 30.1 million inhabitants. Half the population lives in rural areas where only 52 per cent is using adequate sanitation facilities and only 56 per cent has access to reliable drinking water sources.²

Morocco has nine years of compulsory education. The literacy rate in 2007 was 56 per cent, and the net intake rate for primary education in 2006 was 84 per cent.³ Many children do not make it through school before dropping out to work. Studies show that hunger and poor health status result in poor school attendance.⁴

Vulnerability to climate change

In Morocco, the last 30 years of data show frequent and intense droughts, devastating floods, reduction of the snow cover on the Er Rif and Atlas Mountains and changes in rainfall distribution. All are strong evidence of climate change.⁵ Soil salinization is extensive and at risk of increasing. Widespread aridity and risk of desertification are additional challenges.⁶

The climate change scenarios for Morocco produced using the IPCC methodology were particularly harsh. If no global action is taken, the annual average temperature in Morocco will rise by between 0.6° C and 1.1° C by 2020, and annual rainfall will drop on average by 4 per cent as compared to the figures for 2000. The potential impact of climate change on water resources in 2020 would be an average countrywide reduction of 10–15 per cent, and on agriculture a fall in cereal output of 50 per cent in a dry year and 10 per cent in an average year.⁷

According to current climate models, by the end of the century, the average annual precipitation rate is likely to fall by 20 per cent. Higher temperatures will increase the rate at which water in the soil evaporates, exacerbating the summer water shortages that are already a feature of many countries in the region. Increasing water scarcity has a negative impact on agricultural and forestry yields and on the generation of electricity by hydropower. Water resources in the country are already reaching their supply limits. Reduced water resources will impact agriculture and threaten the food security of poor families.

The drought in 1999 affected 275,000 people in the country and had an estimated cost of US\$900 million.⁸ In Morocco, as in many other regions of North Africa, desertification is affecting the most sensitive environments such as the rangelands.

Morocco's forests cover 12 per cent of the country's surface area, and deforestation is advancing at an alarming rate. The country is losing 30,000 hectares every year due to both human activity and changes to the ecosystem linked with climate change, such as increased forest fires.

Unusually devastating floods have been recorded in Morocco in recent years. While many of the smaller, localized floods went uncounted, 13 major flood events were recorded during the last 20 years. The death toll for these events was 1,230, and the total damage in cost is estimated at US\$311 million.

Most of the Atlantic coast of Morocco consists of low-lying lands. These lands are extremely vulnerable to sea level rise, which threatens people, coastal infrastructure and the natural heritage. A climate model constructed for Nador and Berkane Districts has shown that a sea level rise might exceed 90 cms by the year 2100 in parts of the country.⁹

Effects of climate change on children

The impacts on children are wide-ranging, threatening above all their health and food security. Levels of diarrhoea are closely related to water availability and sanitation. For example, a 1990 survey in Morocco revealed a high occurrence of diarrhoea, where 26.8 per cent of surveyed children had had diarrhoea in the previous two weeks.¹⁰ However, in recent years, there have been significant improvements. In 1990, only 14 per cent of Moroccans living in rural areas had access to drinking water from a public source.¹¹ In 2004, this number increased to 56 per cent.¹²

Increased air pollution, triggered by warmer temperatures, is likely to result in an increased risk of asthma among children, although pollution is not the only factor related to asthma.¹³ A study to determine the prevalence of asthma in adolescents in Rabat found asthma in 50 children in a sample of 1,016.¹⁴

Morocco has one of the lowest rates of undernutrition compared to other countries in North Africa and the Middle East – only 6 per cent.¹⁵ This number varies by region, however. Loss of food security connected to reduced water resources and problems in agricultural production are leading to stunting and underweight children, especially in rural areas. In 1997, studies determined that undernourishment among children under five was still prevalent. At that time, the national average for stunting was 23 per cent and 10 per cent of the children were underweight.¹⁶ In 2007, in rural areas, 24 per cent of children under five were stunted.¹⁷

Food security for many children, especially rural children and children living in mountainous areas, is at risk due to climate change unless adaptation projects are implemented and special attention is given to the most vulnerable communities.

Reduction of water and economic hardships are forcing many rural families in Morocco to require support from their children in the form of farm labour or cattle herding. Increased household work due to climate change is putting additional pressure both on boys and girls. Studies conducted in rural villages demonstrated that children play a crucial role in the household economy by fetching water, working in the fields, helping dig irrigation canals, selling poultry at the market, fetching medicines, and herding and milking animals.¹⁸ These activities are often carried out to the detriment of their education.¹⁹

Adaptation strategies

Morocco signed the UNFCCC during the June 1992 United Nations Conference on Environment and Development held in Rio de Janeiro, Brazil. Morocco also submitted its First National Communication on climate change in 2001. It highlighted the country's vulnerability, indicating two key sectors in need of immediate attention, namely, water resources and agriculture. In 2003 an overall national strategy for the environment was developed, which was followed by a national action plan for the environment. Morocco submitted its Second National Communication in 2006.

Morocco has a very complex institutional structure concerning climate change. The main responsibility related to climate change is borne by the Department of Environment. The newly created department has set up a National Environmental Council and regional councils, and has created five separate administrative bodies supported by several national committees. Currently, there is a general agreement that "all these institutions need to be consolidated and their capacities strengthened to fully follow up the implementation of the Conventions related to environmental issues."²⁰

Morocco has developed 12 adaptation projects, mainly addressing the water and agriculture sectors. There is clearly a need to conduct further assessments of the social and economic impacts that are directly relevant to the lives of children. In its submission to UNFCCC in May 2007, Morocco proposed to conduct an evaluation of the vulnerability of socio-economic sectors to climate change.²¹ Unlike large-scale water and agriculture projects, if carried out, these activities will have direct relevance to the issues related to children and climate change. Currently missing in Morocco's overall adaptation policy are the approaches that would help understand the local context and influence of climate change on local ecology.

For Morocco, the overall financial cost of adaptation will be significant. The Government of Morocco, aware of the fact that climate change is causing extra pressure on limited resources, stated:

It is clear that the Moroccan economy which is still caught up in the problems of development and struggles against poverty, cannot withstand the costs of such [adaptation] projects without sacrificing the major components of its social and economic development programs (education, health, basic infrastructures, rural development, etc.).²²

In most cases, such as the coastal adaptation plans, benefits occur in the long run and early losses are expected because of the large 'kick-off' investments that are needed.

Child and youth participation

The number of adaptation projects that involve children in meaningful research and action are quite limited; however, there are some impressive examples such as the project carried out in the Aïn Béni Mathar rural community located north-east of the High Plateaux.²³ Livestock remains the principal source of income in the region. Historical analysis of the grazing lands reveals that non-cultivated vegetation cover has diminished significantly over time. The project organized workshops to discuss land use and flock management with farmers and their families. The knowledge of youth, children and women, who are the primary labourers in this economy, was essential for understanding grazing patterns.

The project also introduced the feed blocks technology by efficiently utilizing a large range of by-products in small ruminant feeding cattle. The technology is simple and does not require sophisticated equipment. Manufacturing and handling of feed blocks is done on the farms, using family labour and youth participation.

Experience shows, in the context of climate change, that it is imperative that policies and programmes draw on the existing body of knowledge on gender and water to inform interventions. There is evidence that simple strategies work. For example, providing local water sources reduces the time required to fetch water and makes domestic tasks faster to complete, thus having a positive impact on school attendance for girls.²⁴ In Morocco, a World Bank Rural Water Supply and Sanitation Project succeeded in increasing girls' school attendance in six provinces by 20 per cent over four years, in part attributable to the reduced burden on young girls to fetch water.²⁵ It is evident that further participatory research with local communities would provide enough convincing evidence to justify the infrastructural costs involved in these types of projects.

At this time, child and youth participation is not a major item on the adaptation agenda. This may relate to the culture and perception of children in Moroccan society. Children's local knowledge of natural resources and climate seems to be undervalued. This is unfortunate, because many case studies strongly demonstrate that older children and youth are major actors in the areas of food security and taking care of household chores. By tradition, boys manage domestic animals and cattle, while girls fetch water, collect firewood and participate in cooking and childcare.

Children and youth are currently referred to in adaptation projects only in relation to awareness-raising. Children are also asked to participate in forestation campaigns.²⁶ Teaching children about climate change, and providing them with knowledge on disaster readiness and management, is a high priority.

Some local and national NGOs seem to have been moving on a more participatory course. For example, RIOD Maroc, a Moroccan network of non-governmental and community-based organizations that struggle against desertification and drought, is initiating a series of participatory action research projects to set priorities in terms of climate change adaptation and test appropriate strategies.²⁷

In countries such as Morocco, where the social roles of girls and boys are clearly defined, it is important to consider gender in child and youth participation. For example, girls and women may have less access to vital information on mitigation or adaptation strategies because of time constraints imposed by their domestic and care-giving responsibilities. Girls are also more likely to be absent than boys from decision-making processes.²⁸

Conclusions

Despite establishing a very complex structure of organizations and committees at the national level, Morocco's major roadblock seems to be the lack of coordination between national- and local-level action. A 2004 case study of Morocco's Plan for Sustainable Development points out this weakness:

It is important to highlight the weakness of functional connections between the national and the local level to facilitate and promote the implementation of the [Plans of Action for Sustainable Development]. Local authorities at present time have not enough capacity to produce short-, medium- and long-term strategies or detailed action plans.²⁹

There is a strong need in Morocco to bring children's issues into the climate change agenda. This might best be done through agencies that are established to protect the rights of children. The Secretariat of State for Family, Solidarity, and Social Action is responsible for coordinating and supervising public policies for children, although its administrative capacity is limited in relation to its assigned tasks. Strengthening the Secretariat and bringing climate change into its agenda may be a solution.

Another key issue is the knowledge gap in relation to research on climate change and children. A survey of available studies on climate change and health, including peer-reviewed

articles, international publications, reports and conference papers in the Eastern Mediterranean Region, revealed a total of 74 resources. The number of resources on Morocco was five, and none of the resources related to children.³⁰

Children living in the most vulnerable communities should be a first priority in the development of national and local adaptation projects. Currently, there is a stronger focus on a sectoral approach in the selection and implementation of adaptation efforts. This needs to be supplemented by research and local adaptation projects that identify localities and the children living in them that are most vulnerable to the effects of climate change.

NOTES

- 1 Morocco, Consommation et dépenses des ménages 1984-85 : Premiers résultats, rapport de synthèse, vol. 1, Direction de la Statistique, Rabat, 1988.
- 2 UNICEF 'Basic Health Statistics: Morocco', <http://www.unicef.org/infobycountry/morocco_statistics.html#43>.
- 3 UNESCO Institute for Statistics, 2008, <<http://stats.uis.unesco.org/unesco/TableViewer/tableView.aspx?ReportId=210>> and <<http://stats.uis.unesco.org/unesco/TableViewer/tableView.aspx?ReportId=183>>, accessed 2 November 2008.
- 4 Atchoarena, D. and L. Gasperini (eds.), *Education for Rural Development: Towards new policy responses*, FAO/UNESCO International Institute for Educational Planning (IIEP), 2003.
- 5 Morocco Initial National Communication, Summary, October 2001.
- 6 German Advisory Council on Global Change (WBGU), *Climate Change as a Security Risk*, Earthscan, London, January 2008.
- 7 Morocco, Paper presented by Taha Balafrej, Director, Department of Partnerships, Cooperation and Communication, Ministry of Regional Development, Water and the Environment, Morocco, 2007.
- 8 EM-DAT, Emergency Events Database, Morocco Country Profile, <www.emdat.be>.
- 9 Adaptation to Climate Change in Morocco Project, 2007, <www.accma.un.ma>.
- 10 WHO Diarrhoeal Diseases Control Programme, *Weekly Epidemiological Record/Relevé épidémiologique hebdomadaire*, vol. 66, no. 13, 29 March 1991, pp. 89-91.
- 11 Boelee, E. and H. Laamrani, 'Multiple Use of Irrigation Water in Northern Morocco', Paper submitted to the International Symposium on Water, Poverty and Productive Uses of Water at the Household Level, Muldersdrift, South Africa, 2003.
- 12 UNICEF, Basic Health Statistics: Morocco, <www.unicef.org/infobycountry/morocco_statistics.html#43>.
- 13 Houssaini, A. S. et al., 'Air Pollution as a Determinant of Asthma Among Schoolchildren in Mohammedia, Morocco', *International Journal of Environmental Health Research*, vol. 17, no. 4, 2007, pp. 243-257.
- 14 Bennis, A. et al., 'The Prevalence of Adolescent Asthma in Rabat: A survey conducted in secondary schools', in French, *Revue des maladies respiratoires*, vol. 9, no. 2, 1992, pp. 163-169.
- 15 Galal, O., 'Nutrition-related health patterns in the Middle East', *Asia Pacific Journal of Clinical Nutrition*, vol. 12, no. 3, 2003, pp. 337-343.
- 16 Benjelloun, S., 'Nutrition transition in Morocco', *Public Health Nutrition*, vol. 5, no. 1A, 2002, pp. 135-140.
- 17 WHO, *World Health Statistics*, 2007 (data from 2004), <www.who.int/whosis/database/core/core_select_process.cf?countries=mar&indicators=child_undernutrition>.
- 18 El Mdaghri, C. A., 'Women, Environment and Population: A Moroccan case study', *IDS Bulletin*, vol. 26, no. 1, 1995, pp. 61-65.
- 19 'Survival, Change and Decision-Making in Rural Households: Three village case studies from eastern Morocco', <www.ifad.org/gender/thematic/morocco/mo_2.htm>.
- 20 Morocco, First National Communication, United Nations Framework Convention on Climate Change, Executive Summary, October 2001, p. 18.
- 21 Relevant programmes, activities and views on the issues relating to climate-related risks and extreme events, Morocco's submission to UNFCCC, Mission II adaptation activities, May 2007.
- 22 Morocco First National Communication, Executive Summary, op. cit., p. 11.
- 23 This study was undertaken within the context of the project 'Sustainable Management of the Agro-Pastoral Resource Base in the Oujda Region (Morocco): A regional approach' funded by the Swiss Agency for Development and Cooperation, and jointly implemented by the International Center for Agricultural Research in the Dry Areas and the French National Institute for Agricultural Research, Oujda, Morocco.
- 24 'Gender and Climate Change, Mapping the Linkages: A scoping study on knowledge and gaps', paper prepared for the UK Department for International Development by Brody, Alyson, Justina Demetriades and Emily Epslen, BRIDGE, Institute of Development Studies, United Kingdom, 2008.
- 25 Fisher, J., 'For Her It's the Big Issue: Putting women at the centre of water supply, sanitation and hygiene', Water Supply and Sanitation Collaborative Council, March 2006, p. 15.
- 26 'One Woman, Two Trees: Planting trees for improving living conditions', for details see <www.neareast.org/main/explore/cds/ppd/en/cs.asp?country=12&content=p2>.
- 27 'Engaging Action Research in Adaptation to Climate Change at the Community Level in Morocco', for project description and details see <www.idrc.ca/ar/ev-83275-201_104876-1-IDRC_ADM_INFO.html>.
- 28 BRIDGE, Institute of Development Studies, Gender and Climate Change: Mapping the linkages, BRIDGE/IDS for UK Department of Development Studies, March 2008.
- 29 Tarradell, M., Morocco Case Study: Analysis of national strategies for sustainable development, National Strategies for Sustainable Development: Challenges, approaches, and innovations based on a 19-country analysis, 2004.
- 30 Climate change and health in the EMR: The knowledge gap, Presentation to the Regional Workshop on Adaptation Strategies. Amman, Jordan, December 2006.

ANNEX C

REFERENCES TO THE ENVIRONMENT IN THE CONVENTION ON THE RIGHTS OF THE CHILD

The Convention on the Rights of the Child includes the following references:

Preamble

The States Parties to the present Convention,

...*Convinced* that the family, as the fundamental group of society and the natural environment for the growth and well-being of all its members and particularly children, should be afforded the necessary protection and assistance so that it can fully assume its responsibilities in the community.

Article 24

1. States Parties recognize the right of the child to the enjoyment of the highest attainable standard of health and to facilities for the treatment of illness and rehabilitation of health. States Parties shall strive to ensure that no child is deprived of his or her right of access to such health care services.
2. States Parties shall pursue full implementation of this right and, in particular, shall take appropriate measures:...
 - (c) To combat disease and malnutrition, including within the framework of primary health care, through, *inter alia*, the application of readily available technology and through the provision of adequate nutritious foods and clean drinking-water, taking into consideration the dangers and risks of environmental pollution;...
 - (e) To ensure that all segments of society, in particular parents and children, are informed, have access to education and are supported in the use of basic knowledge of child health and nutrition, the advantages of breastfeeding, hygiene and environmental sanitation and the prevention of accidents.

Article 29

1. States Parties agree that the education of the child should be directed to:...
 - (e) The development of respect for the natural environment.

In the context of the state reporting procedure, the Committee on the Rights of the Child has issued observations calling for better compliance with article 24(2)(c). In its Concluding Observations on the state report submitted by Jordan, for example, the Committee recommended that Jordan “take all appropriate measures, including through international cooperation, to prevent and combat the damaging effects of environmental pollution and contamination of water supplies on children and to strengthen procedures for inspection.”¹

The Concluding Observations on South Africa expressed the Committee’s “concern...at the increase in environmental degradation, especially as regards air pollution” and “recommend[ed] that the State party increase its efforts to facilitate the implementation of sustainable development programmes to prevent environmental degradation, especially as regards air pollution.”²

NOTES

1 Committee on the Rights of the Child, Concluding Observations on Jordan, UN Doc. CRC/C/15/Add.125 at para. 50 (2000).

2 Committee on the Rights of the Child, Concluding Observations on South Africa, UN Doc. CRC/C/15/Add.122 (200) at para. 30.

ANNEX D

AN EXAMPLE OF LOCAL ADAPTATION IN KENYA

The UNICEF-supported school-feeding programme in Kenya is an essential element in the education of pastoral children. But it also has a potentially negative environmental impact, as it uses significant amounts of firewood.

A primary school with 400 children uses the equivalent of at least about one medium-sized tree per week. This translates to about 36 trees each year. Three hundred such schools, in the West Pokot District of Kenya's Rift Valley, would require 10,800 trees each year. In 12 arid and semi-arid districts the total figure is a staggering 129,600 trees per year, or 1.3 million trees in 10 years.

Meanwhile, apart from domestic use, there has been widespread burning of wood to make charcoal on a commercial basis in all these districts, as one of the drought-coping mechanisms. Thousands of trees are cut each year in each district.

The situation has serious implications for water resource management. For instance, West Pokot lies within the catchment areas of the Kerio and Turkwell Rivers that drain into Lake Turkana. Sustaining flow in these rivers is important for food and water security in both the West Pokot and Turkana Districts. Streams that just 10 years ago were considered permanent, sustaining flow even during significant drought events, are now seasonally impacting the water supply due to decreased flow.

Even without the school-feeding programme the catchments would require rehabilitation. The Kerio Valley Development Authority estimates that in order for the environment to be rehabilitated and sustainability assured, the schools and the population in West Pokot would need to plant at least 10 times the number of trees they cut each year. The schools would have to plant about 1 million trees in 10 years; and the wider population would have to plant some 4 million trees in 10 years.

The next generation must be empowered to take care of the environment more responsibly than the current generation if the water sources are to be sustainable. Schoolchildren are an important constituency for the achievement of this goal, and promoting proper environmental management will be much easier when children complete their education with that knowledge.

The solution found calls for schoolchildren to take up the challenge of reforesting the environment in or around their schools. To reduce the time and effort required, "one child [is] to plant one tree and take care of it for one year, and then plant another next year and so on until he/she leaves school." The solar-generated water systems developed offer the opportunity for schools to maintain and ensure the survival of trees planted. At the same time, the water can be used to establish tree nurseries and vegetable gardens at the schools that would conveniently supply trees and food to schools and households at little cost.

Bibliography

■ UNICEF and related documents and publications

- United Nations Children's Fund, *The State of the World's Children 2008: Child survival*, UNICEF, New York, December 2007.
- United Nations Children's Fund, *Climate Change and Children*, UNICEF, New York, December 2007.
- United Nations Children's Fund, *Progress for Children: A World Fit for Children statistical review*, no. 6, UNICEF, New York, December 2007.
- United Nations Children's Fund, *Children and the Millennium Development Goals: Progress towards a World Fit for Children*, UNICEF, New York, December 2007.
- United Nations Children's Fund Innocenti Research Centre, *The General Measures of the Convention on the Rights of the Child: The process in Europe and Central Asia*, UNICEF IRC, Florence, 2006.
- United Nations Children's Fund, *Progress for Children: A Report Card on Water and Sanitation*, no. 5, UNICEF, New York, September 2006.
- United Nations Children's Fund, 2006. 'UNICEF: Water, sanitation and hygiene strategies for 2006-2015', E/ICEF/2006/6, United Nations Children's Fund, Executive Board, first regular session, New York, 2006.
- United Nations Children's Fund, *Core Commitments for Children in Emergencies*, UNICEF, New York, 2005.
- UNICEF Eastern and Southern Africa Regional Meeting on Child Participation in WES Final Report, UNICEF Nairobi, 2006.
- United Nations Children's Fund East Asia and Pacific Regional Office, *Emergencies: Refugees, IDPs and child soldiers – Natural disasters*, UNICEF EAPRO, Bangkok, 2005.
- United Nations Children's Fund, *The State of the World's Children 2003: Child participation*, UNICEF, New York, 2002.
- Back, E. and C. Cameron, *Our Climate, Our Children, Our Responsibility: The implications of climate change for the world's children*, UNICEF United Kingdom, London, 2008.
- Black, M. and R. Talbot, *Water – A matter of life and health*, United Nations Children's Fund, Oxford University Press, 2005.
- Bajracharya, D., 'Primary Environmental Care for Sustainable Livelihood: A UNICEF perspective', *Childhood*, vol. 2, no. 1-2, 1994, pp. 41-55.
- Cando, Lee, 'UNICEF and Climate change', Youth Discussion Paper, January 2008.
- Fountain, S., for United Nations Children's Fund, Education for Development Unit, *It's Only Right! A Practical Guide to Learning about the Convention on the Rights of the Child*, UNICEF New York and Geneva, 1999.
- Goodman, D., Child Participation in Water, Environment and Sanitation (WES) in Tajikistan, United Nations Children's Fund, Water, Environment and Sanitation Section/Programme Division, 2004.
- Hart, R., *Children's Participation: The theory and practice of involving young children in community development and environmental care*, United Nations Children's Fund, Earthscan, London, 1997.
- Hart, R. et al., *The Environment for Children: Understanding and acting on the environmental hazards that threaten children and their parents*, United Nations Children's Fund, Earthscan, London, 1996.
- Ives, Dr. Jack, for United Nations Children's Fund, 'Children, Environment and Sustainable Development', Primary Environmental Care (PEC), Discussion Paper No. 2, 1996.
- Jansen, M., 'Children and the Environment: Environment – Integral to a comprehensive approach to child survival, protection and development', United Nations Children's Fund, Programme Division Working Paper, PD-98-001, July 1998.
- McKee, N. et al. (eds.), *Involving People, Evolving Behaviour*, UNICEF, New York, 2000.
- Taylor-Ide, D. and C. Taylor, for United Nations Children's Fund, 'Community Based Sustainable Human Development: A proposal for going to scale with self-reliant social development', Children, Environment and Sustainable Development, Primary Environmental Care (PEC), Discussion Paper No. 1, 1995.
- United Nations Children's Fund, *Children and Agenda 21: A guide to UNICEF issues in the Earth Summit's blueprint for development and environment in the 21st century*, UNICEF, Geneva, 1992.
- United Nations Children's Fund, *Environment, Development and the Child*, UNICEF, New York, 1992.
- United Nations Economic and Social Council, 'Children, Environment and Sustainable Development: UNICEF response to Agenda 21', E/ICEF/1993/L.2, United Nations Children's Fund, Executive Board, 1993 session, New York, 1993.
- United Nations Children's Fund, Programme Committee, 'Draft Recommendation Submitted to the Programme Committee by the Drafting Session on Document E/ICEF/1993/WP8', Decision 1993/14, E/ICEF/1993/CRP.30, UNICEF, 6 May 1993.
- United Nations Children's Fund, *Poverty Reduction Begins with Children*, UNICEF, New York, 2000.
- United Nations Children's Fund, *Towards a Baseline: Best estimates of social indicators for Southern Sudan*, New Sudan Centre for Statistics and Evaluation, Series Paper, 2004.

■ UNEP documents and publications

- United Nations Environment Programme, *Africa Environment Outlook 2: Our environment, our wealth*, Executive Summary, UNEP, Nairobi, 2006.
- United Nations Environment Programme, *GEO Yearbook: An overview of our changing environment 2006*, UNEP, 2006.
- United Nations Environment Programme, 'Deserts and Desertification: Don't desert drylands!', World Environment Day, 2006.
- United Nations Environment Programme, High-Level Forum of the United Nations Environment Management Group, Discussion Paper by the Chair, UNEP, 2006.
- Foresman, J., *My Community, Our Earth: A student project guide to sustainable development and geography*, United Nations Environment Programme, 2002.
- United Nations Environment Programme, Governing Council, 'Mid-term progress report on the implementation of the long term strategy on engagement and involvement of young people in environmental issues', UNEP/GCSS.IX/7, November 2005.
- United Nations Environmental Programme, *Ethics and Agenda 21: Moral implications of a global consensus*, UN Publications, New York, 1994.
- United Nations Environment Programme, *Pachamama, Our Earth, Our Future*, UNEP with Peace Child International, 1999.

■ WHO documents and publications

- World Health Organization, Campbell-Lendrum, Diarmid, Carlos Corvalán and Maria Neira, 'Global Climate Change: Implications for international public health policy', *Bulletin of the World Health Organization*, vol. 85, no. 3, March 2007.
- World Health Organization, *Fuel for Life: Household energy and health*, WHO, Geneva, 2006.
- World Health Organization, Diarrhoeal Diseases Control Programme, *Weekly Epidemiological Record/Relevé épidémiologique hebdomadaire*, vol. 66, no. 13, March 1991, pp. 89-91.
- World Health Organization, *Ecosystems and Human Well-Being: Health synthesis*, Millennium Ecosystem Assessment, WHO, Geneva, 2005.

- World Health Organization, Gordon, B., R. Mackay and E. Rehfuss, *Inheriting the World: The ATLAS of children's health and the environment*, Myriad Editions UK for WHO, 2004.
- World Health Organization, *Global Environmental Change and Health: Risks and responses*, WHO, Geneva, 2003.
- World Health Organization, in collaboration with the United Nations Environment Programme and World Meteorological Organization, *Climate Change and Human Health: Risks and responses – Summary*, WHO, Geneva, 2003.
- World Health Organization, *World Health Report 2002: Reducing risks, promoting healthy life*, WHO, Geneva, 2002.
- Briggs, D., *Making a Difference: Indicators to improve children's environmental health*, WHO, Geneva, 2003.
- Pronczuk, J. and M. Shimkin, *National Profiles on Children's Health and the Environment: Assessing readiness for improving environmental health protection and chemical safety for children*, World Health Organization, 2005.
- Pronczuk de Garbino, J., *Children's Health and the Environment, A Global Perspective: A resource manual for the health sector*, World Health Organization, Geneva, 2006.
- Prüss-Üstün, A., and C. Corvalán, C., *Preventing Disease Through Healthy Environments: Towards an estimate of the environmental burden of disease*, World Health Organization, Geneva, 2006.
- Wisner, B. and J. Adams, *Environmental Health in Emergencies and Disasters*, World Health Organization/United Nations High Commissioner for Refugees/International Federation of Red Cross and Red Crescent Societies/International Strategy for Disaster Reduction, World Health Organization, Geneva, 2002.
- World Health Organization, *The World Health Report 2002: Reducing risks and promoting healthy life*, WHO, Geneva, 2002.
- World Health Organization, The 2007 David E. Barmes Global Health Lecture, 'Climate Change and Health: Preparing for unprecedented challenges', Director-General Dr. Margaret Chan, Bethesda, Maryland, United States, 2007.
- Other United Nations system documents and publications**
- Atchoarena, D. and L. Gasperini (eds.), *Education for Rural Development: Towards new policy responses*, United Nations Food and Agriculture Organization/United Nations Educational, Scientific and Cultural Organization International Institute for Educational Planning, 2003.
- Office of the Special Representative of the Secretary-General for Children and Armed Conflict, Global Youth Action Network, United Nations Children's Fund, United Nations Population Fund and Women's Commission for Refugee Women and Children, "Will You Listen?"; *Young Voices from Conflict Zones*, October 2007.
- United Nations International Strategy for Disaster Reduction, '2006-2007 World Disaster Reduction Campaign: Disaster risk reduction begins at school', UN/ISDR, Geneva, 2006.
- Fabra, A., 'The Intersection of Human Rights and Environmental Issues: A review of institutional developments at the international level', Background Paper No. 3, United Nations Environment Programme and Office of the High Commissioner for Human Rights Expert Seminar on Human Rights and the Environment, Geneva, January 2002.
- Shelton, D., 'Human Rights and Environment Issues in Multilateral Treaties Adopted Between 1991 and 2001', Background Paper No. 1, United Nations Environment Programme and Office of the High Commissioner for Human Rights Expert Seminar on Human Rights and the Environment, Geneva, January 2002.
- Shelton, D., 'Human Rights and the Environment: Jurisprudence of human rights bodies', Background Paper No. 2, United Nations Environment Programme and Office of the High Commissioner for Human Rights Expert Seminar on Human Rights and the Environment, Geneva, January 2002.
- Sudan's First National Communication under the United Nations Framework Convention on Climate Change, vol. 1, 2003.
- Sudan's Second National Communication to the United Nations Framework Convention on Climate Change, United Nations Development Programme, 2007.
- United Nations System, Chief Executives Board for Coordination, 'Coordinated UN System Action on Climate Change: Charting the way forward', UN, Department of Public Information, New York, November 2007.
- United Nations Foundation/Club of Madrid, *Global Leadership for Climate Action: A proposal framework for a post-2012 agreement on climate change*, 2007.
- United Nations Development Programme, *Gender and Energy for Sustainable Development: A toolkit and resource guide*, UNDP, New York, 2004.
- United Nations Development Programme, *Human Development Report 2006: Beyond scarcity – Power, poverty and the global water crisis*, UNDP, New York, 2006.
- United Nations Development Programme, *Human Development Report 2007/2008: Fighting Climate Change: Human solidarity in a divided world*, UNDP, New York, 2007.
- United Nations Development Programme, Project of the Government of Sudan, The Preparation of a National Programme of Action, UNDP, 2003.
- United Nations Development Programme, Energy and Environment Group, *Making Progress on Environmental Sustainability: Lessons and recommendations from a review of over 150 MDG country experiences*, UNDP, New York, 2006.
- United Nations Department of Economic and Social Affairs, *Trends in Sustainable Development*, UN, New York, 2006.
- United Nations Educational, Scientific and Cultural Organization, 'Education for Sustainable Development in Action: Guidelines and recommendations for reorienting teacher education to address sustainability', Technical Paper No. 2, UNESCO Education Sector, October 2005.
- United Nations Framework Convention on Climate Change, *Initial National Communications: Algeria*, 2001.
- United Nations Framework Convention on Climate Change, *Initial National Communications: Morocco*, 2001.
- United Nations Framework Convention on Climate Change, *Initial National Communications: Mozambique*, 2003.
- United Nations Framework Convention on Climate Change, *Initial National Communications: Sudan*, 2003.
- United Nations Framework Convention on Climate Change, *National Adaptation Programme of Action: Sudan*, 2007.
- United Nations Framework Convention on Climate Change, *Initial National Communications: Tunisia*, 2001.
- United Nations Children's Fund, World Health Organization, Joint Monitoring Programme, *Meeting the MDG Drinking Water and Sanitation Target: A mid-term assessment of progress*, UNICEF/WHO, 2006.
- United Nations Children's Fund, United Nations Environment Programme, *The State of the Environment: Children and the environment*, UNICEF/UNEP, 1990.
- United Nations Children's Fund and partners, *Rescue Mission Planet Earth: A children's edition of Agenda 21*, UNICEF/UNEP/UNDP/UNESCO/Foundation for Environmental Awareness, 1994.
- United Nations Children's Fund, United Nations Development Programme, *Children and Sustainable Development: Partnerships in capacity building – Capacity 21 Programme*, UNICEF/UNDP, 1996.
- United Nations Children's Fund and partners, *A Call to Action: Using indicators to measure progress on children's environmental health*, 2002.
- United Nations Children's Fund, World Health Organization, United Nations Environment Programme, *Children in the New Millennium: Environmental impact on health*, UNICEF/WHO/UNEP, 2002.

Other agency publications

- Cairncross, S. et al., *Health, Environment and the Burden of Disease: A guidance note*, Department for International Development, United Kingdom, February 2003.
- Commission for Environmental Cooperation, *Children's Health and the Environment in North America: A first report on available indicators and measures*, Commission for Environmental Cooperation, Montreal, January 2006.
- German Advisory Council on Global Change (WGBU), *Climate Change as a Security Risk*, Earthscan, London, 2008.
- Organisation for Economic Co-operation and Development, *The Benefits of Climate Change Policies*, OECD, Paris, 2004.
- United Nations Department of Economic and Social Affairs, Division for Sustainable Development, Commission on Sustainable Development, fourteenth session (CSD-14), Report of the Netherlands for CSD-14, 'Review of sustainable development for energy, industrial development and air quality', 2006.

Youth participation

- Rescue Mission Planet Earth 2002: Children celebrating progress towards sustainable development*, Peace Child International/Government of Finland, 2002.
- United Nations Children's Fund, 'Child Participation' in *The State of the World's Children 2003*, UNICEF, 2002.
- United Nations Children's Fund Regional Office for South Asia, *Wheel of Change: Children and young people's participation in South Asia*, UNICEF, 2004.
- United Nations Department of Economic and Social Affairs, 'The Global Situation of Young People', *World Youth Report 2003*, UNECOSOC, New York.
- United Nations Children's Fund/Commonwealth Secretariat, *Tools for Adolescent and Youth Participation*, UNICEF/Commonwealth Secretariat, 2005.
- United Nations Children's Fund/Commonwealth Secretariat, *Adolescent Participation and the Project Cycle*, UNICEF/Commonwealth Secretariat, 2005.
- United Nations Children's Fund/Joint United Nations Programme on HIV/AIDS/United Nations Population Fund, *Investing When It Counts: Generating the evidence base for policies and programmes for very young adolescents – Guide and toolkit*, UNICEF/UNAIDS/UNFPA, 2006.
- World Bank, 'Development and the Next Generation' *World Development Report 2007*, World Bank, Washington, D.C., 2007.
- World Bank, 'Children and Youth: A framework for action', Children and Youth Development Hub, World Bank, Washington, D.C., 2005.

Sectoral dimensions

- Abbasi, D., *Americans and Climate Change: Closing the gap between science and action*, Yale School of Forestry and Environmental Studies, United States, 2006.
- Abdelmoneium, A. O., 'Challenges Facing Children in Education and Labour: Case study of displaced children in Khartoum-Sudan', *Ahfad Journal*, vol. 22, no. 2, 2005, pp. 64-76.
- Alsop, Z., 'Malaria returns to Kenya's highlands as temperatures rise', *The Lancet*, vol. 370, no. 9591, 2007, pp. 925-926.
- Anderson, P. et al., *Climate Change Futures: Health, ecological and economic dimensions*, The Center for Health and the Global Environment, Harvard Medical School, Cambridge, United States, 2006.
- Awad, E. L. et al., 'Social and public health implication of water supply in arid zones in the Sudan', *Social Science & Medicine*, vol. 20, no. 4, 1985, pp. 393-398.
- Barker, D. J. P., 'Maternal nutrition, fetal nutrition, and disease in later life', *Nutrition*, vol. 13, no. 9, Sept. 1997, pp. 807-813.
- Barker, D. J. P. et al., 'Trajectories of growth among children who have coronary events as adults', *New England Journal of Medicine*, vol. 353, 2005, pp. 1802-1809.

- Barnett, Jon, 'Security and Climate Change', *Global Environmental Change*, vol. 13, no. 1, April 2003, pp. 7-17.
- Bartlett, S., *Climate Change and Urban Children: Implications for adaptation in low and middle income countries*, International Institute for Environment and Development, London, 2008.
- Bennis, A. et al., 'The Prevalence of Adolescent Asthma in Rabat: A survey conducted in secondary schools', in French, *Revue des maladies respiratoires*, vol. 9, no. 2, 1992, pp. 163-169.
- Benjelloun, S., 'Nutrition transition in Morocco', *Public Health Nutrition*, vol. 5, no. 1A, 2002, pp. 135-140.
- Biddlecom, A. E., W. Axinn and J. S. Barber, 'Environmental Effects on Family Size Preferences and Subsequent Reproductive Behavior in Nepal', *Population and Environment*, vol. 26, no. 3, 2005, pp. 583-621.
- Blum, L. N., L. B. Bresolin and M. A. Williams, 'Heat-related illness during extreme weather emergencies', *Journal of the American Medical Association*, vol. 279, no. 19, May 1998, p. 1514.
- Boelee, E. and H. Laamrani, 'Multiple Use of Irrigation Water in Northern Morocco', Paper submitted to the International Symposium on Water, Poverty and Productive Uses of Water at the Household Level, 2003.
- Campbell-Lendrum, D. and R. Woodruff, 'Climate Change: Quantifying the health impact at national and local levels', *Environmental Burden of Disease Series*, no. 14, World Health Organization, 2007.
- Cannon, T., 'Gender and climate hazards in Bangladesh', *Gender & Development*, vol. 10, no. 2, July 2002, pp. 45-50.
- Chatterjee, P., 'Mopping up in Mumbai', *The Lancet*, vol. 366, no. 9488, September 2005, p. 795.
- Checkley, W. et al., 'Effects of El Niño and ambient temperature on hospital admissions for diarrhoeal diseases in Peruvian children', *The Lancet*, vol. 355, no. 9202, February 2000, pp. 442-450.
- Claeson, M. et al., 'Reducing child mortality in India in the new millennium', *Bulletin of the World Health Organization*, vol. 78, no. 10, 2000, pp. 1192-1199.
- Coombs, A., 'Climate change concerns prompt improved disease forecasting', *Nature Medicine*, vol. 14, no. 1, 2008, p. 3.
- Crimmins, E. and C. Finch, 'Infection, inflammation, height, and longevity', *Proceedings of the National Academy of Sciences*, vol. 103, no. 2, 2006, pp. 498-503.
- Curtis, T., B. C. Miller and E. H. Berry, 'Changes in reports and incidence of child abuse following natural disasters', *Child Abuse and Neglect*, vol. 24, no. 9, 2000, pp. 1151-1162.
- Doocy, S. et al., 'Tsunami Mortality Estimates and Vulnerability Mapping in Aceh, Indonesia', *American Journal of Public Health*, vol. 97, 2007, pp. S146-S151.
- Douben, N., Flood Management Lecture Notes, HH 510/02/1IHE, Delft, the Netherlands, 2002.
- Ebi, K., N. Lewis and C. Corvalán, *Climate Variability and Change and Their Health Effects in Small Island States: Information for adaptation planning in the health sector*, United Nations Environment Programme, World Health Organization and World Meteorological Organization, Geneva, 2005.
- Ebi, K., B. Lim and Y. Aguilar, 'Scoping and Designing an Adaptation Project', Technical Paper 1, *Adaptation Policy Framework for Climate Change: Developing strategies, policies and measures*, Cambridge University Press, New York, 2005, pp. 33-46.
- El-nagar, S. E., 'The Impact of War on Women and Children: Case study of Sudan', *Women 2000*, vol. 5, June 1992, pp. 9-11.
- Emmelin, A. and S. Wall, 'Indoor Air Pollution: A poverty-related cause of mortality among the children of the world', *CHEST*, vol. 132, no. 5, 2007, pp. 1615-1623.
- Eriksen, S., 'Linkages between climate change and desertification in East Africa', *Arid Lands Newsletter*, no. 49, May/June 2001.

- Ezzati, M., et al., *Comparative Quantification of Health Risks: Global and regional burden of disease attributable to selected major risk factors*, vols. 1 and 2, World Health Organization, Geneva, 2004, p. 2235.
- Faisal, I. M. and M. R. Kabir, 'An Analysis of Gender-Water Nexus in Rural Bangladesh', *Journal of Developing Societies*, vol. 21, no. 1/2, June 2005, pp. 175-194.
- Fisher, J., 'For Her It's the Big Issue: Putting women at the centre of water supply, sanitation and hygiene', Water Supply and Sanitation Collaborative Council, Geneva, 2006.
- Friedman, J. F. et al., 'Malaria and Nutritional Status Among Pre-school Children: Results from cross-sectional surveys in western Kenya', *American Journal of Tropical Medicine and Hygiene*, vol. 73, no. 4, 2005, pp. 698-704.
- Gautam, K. P. and E. E. van der Hoek, 'Literature Study on Environmental Impact of Floods', GeoDelft, Delft, the Netherlands, June 2003, p. 57.
- German Advisory Council on Global Change (WBGU), *Climate Change as a Security Risk*, Earthscan, London, 2008.
- Giles, J., 'Climate Change 2007: How to survive a warming world', *Nature*, vol. 446, no. 7137, 2007, pp. 716-717.
- Gjertsen, H., 'Can Habitat Protection Lead to Improvements in Human Well-Being? Evidence from marine protected areas in the Philippines', *World Development*, vol. 33, no. 2, 2005, pp. 199-217.
- Guha-Sapir, D., D. Hargitt and P. Hoyois, *Thirty Years of Natural Disasters 1974-2003: The numbers*, Centre for Research on the Epidemiology of Disasters, 2004.
- Haines, A. et al., 'Climate Change and Human Health: Impacts, vulnerability, and mitigation', *The Lancet*, vol. 367, 2006, pp. 2101-2109.
- Hart, R., *Children's Participation: The theory and practice of involving young citizens in community development and environmental care*, Earthscan, London, 1997.
- Hashimoto, M. et al., 'Influence of climate factors on emergency visits for childhood asthma attack', *Pediatrics International*, vol. 46, no. 1, 2004, pp. 48-52.
- Hashizume M. et al., 'Rotavirus Infections and Climate Variability in Dhaka, Bangladesh: A time-series analysis', *Epidemiology and Infection*, November 2007, pp. 1-9.
- Houssaini, A. S. et al., 'Air pollution as a determinant of asthma among schoolchildren in Mohammedia, Morocco', *International Journal of Environmental Health Research*, vol. 17, no. 4, 2007, pp. 243-257.
- Huq, S. et al., 'Mainstreaming Adaptation to Climate Change in Least Developed Countries (LDCS)', International Institute for Environment and Development, London, April 2003.
- Iltus, S., 'Community Participation for Understanding and Improving the Physical Environment of Schools for Children', Report submitted to Save the Children Sweden, 2007.
- Kearney, M., 'Tsunami Orphans', *U.S. News & World Report*, vol. 138, no. 3, 2005, pp. 28-29.
- Kempe, Ronald H., 'Child survival, poverty, and labor in Africa', *Journal of Children & Poverty*, vol. 11, no. 1, 2005, pp. 19-42.
- Kilabuko J. H and S. Nakai, 'Effects of Cooking Fuels on Acute Respiratory Infections in Children in Tanzania', *International Journal of Environmental Research and Public Health*, vol. 4, no. 4, 2007, pp. 283-288.
- Kim J. J., 'Ambient Air Pollution: Health hazards to children', *Pediatrics*, vol. 114, 2004, pp. 1699-1707.
- Lam, L.T., 'The association between climatic factors and childhood illnesses presented to hospital emergency among young children', *International Journal of Environmental Health Research*, vol. 17, no. 1, 2007, pp. 1-8.
- Lambrou, Yianna and Grazia Piana, Gender and Population Division, Sustainable Development Department, *Gender: The missing component of the response to climate change*, United Nations Food and Agriculture Organization, Rome, April 2006.
- Lopez, A. D. et al., 'Global and Regional Burden of Disease and Risk Factors, 2001: Systematic analysis of population health data', *The Lancet*, vol. 367, 2006, pp. 1747-1757.
- Majkowska-Wojciechowska, B. et al., 'Prevalence of allergy, patterns of allergic sensitization and allergy risk factors in rural and urban children', *Allergy*, vol. 62, no. 9, 2007, pp. 1044-1050.
- Masahiro, H. et al., 'Association Between Climate Variability and Hospital Visits for Non-Cholera Diarrhoea in Bangladesh: Effects and vulnerable groups', *International Journal of Epidemiology*, vol. 36, no. 5, 2007, pp. 1030-1037.
- Mathieu-Nolf, M., 'Poisons in the Air: A cause of chronic disease in children', *Journal of Toxicology – Clinical Toxicology*, vol. 40, no. 4, 2002, p. 483.
- Merchant, A.T. et al., 'Water and sanitation associated with improved child growth', *European Journal of Clinical Nutrition*, vol. 57, no. 12, 2003, pp. 1562-1568.
- Mihrshahi, S. et al., 'Prevalence of Exclusive Breastfeeding in Bangladesh and Its Association with Diarrhoea and Acute Respiratory Infection: Results of the multiple indicator cluster survey 2003', *Journal of Health, Population and Nutrition*, vol. 25, no. 2, 2007, pp. 195-204.
- Mitchell, L. M., 'Body and Illness: Considering Visayan Filipino children's perspectives within local and global relationships of inequality', *Medical Anthropology*, vol. 25, no. 4, 2006, pp. 331-373.
- Mugisha, F., 'School Enrollment Among Urban Non-slum, Slum and Rural children in Kenya: Is the urban advantage eroding?', *International Journal of Educational Development*, vol. 26, no. 5, 2006, pp. 471-482.
- Munasinghe, M. et al., 'Applicability of Techniques of Cost-Benefit Analysis to Climate Change', Global Climate Change: Economic and policy issues, World Bank Environment Paper Number 12, World Bank, Washington, D.C., 1995, pp. 33-82.
- Nelson, V. et al., 'Uncertain Predictions, Invisible Impacts, and the Need to Mainstream Gender in Climate Change Adaptations', *Gender and Development*, vol. 10, no. 2, July 2002, pp. 51-59.
- Orr, D., *Earth in Mind: On education, environment and the human prospect*, Island Press, Washington, D.C., 1994.
- Osman-Elasha, B. et al., 'Adaptation Strategies to Increase Human Resilience Against Climate Variability and Change: Lessons from the arid regions of Sudan, Assessment of Impacts and Adaptations to Climate Change, Working Paper No. 42, October 2006.
- Pascual, M. et al., 'Cholera Dynamics and El Niño-Southern Oscillation', *Science*, vol. 289, no. 5485, September 2000, pp. 1766-1769.
- Parashar, U. D. et al., 'Global illness and deaths caused by rotavirus disease in children', *Emerging Infectious Diseases*, 2003, pp. 565-572.
- Pielke, R., Jr. et al., 'Climate Change 2007: Lifting the taboo on adaptation', *Nature*, vol. 445, February 2007, pp. 597-598.
- Pradhan, E. K. et al., 'Risk of flood-related mortality in Nepal', *Disasters*, vol. 31, no. 1, 2007, pp. 57-70.
- Proctor, L. J. et al., 'Family context and young children's responses to earthquake', *Journal of Child Psychology and Psychiatry*, vol. 48, no. 9, 2007, pp. 941-949.
- Prüss-Üstün, A. and C. Corvalán, 'Preventing Disease Through Healthy Environments: Towards an estimate of the environmental burden of disease', World Health Organization, Geneva, 2006.
- Rashid, S. F., 'The Urban Poor in Dhaka City: Their struggles and coping strategies during the floods of 1998', *Disasters*, vol. 24, no. 3, 2000, p. 240.
- Rogers, D. J. and S. E. Randolph, 'The global spread of malaria in a future, warmer world', *Science*, vol. 289, 2000, pp. 1763-1766.
- Scrimshaw, N., 'Historical concepts of interactions, synergism and antagonism between nutrition and infection', *Journal of Nutrition*, vol. 133, no. 1, 2003, pp. 316S-321S.

- Shamim, I. and K. Salahuddin, 'Energy and Water Crisis in Rural Households: Linkages with women's work and time', *Women For Women*, Dhaka, 1994.
- Shea, K. M., 'Global Environmental Changes and Children's Health: Understanding the challenges and finding solutions', *Journal of Pediatrics*, vol. 143, 2003, pp. 149-154.
- Shyamsundar, P., 'Poverty-Environment Indicators, Environmental Economics Series', Paper No. 84, World Bank, Washington, D.C., January 2002.
- Salazar-Lindo, E. and P. Pinell-Salles, 'El Niño and diarrhoea and dehydration in Lima, Peru', *The Lancet*, vol. 350, no. 9091, 1997, p. 1597.
- Shelton, D., United Nations Environment Programme and Office of the United Nations High Commissioner for Refugees, Expert Seminar on Human Rights and the Environment, Background Paper No. 2, 'Human Rights and the Environment: Jurisprudence of Human Rights Bodies', Geneva, 2002.
- Smith, D. and J. Vivekananda, *A Climate of Conflict: The links between climate change, peace and war*, International Alert, London, November 2007.
- Spiegel, P. et al., 'Health Programmes and Policies Associated with Decreased Mortality in Displaced People in Post-Emergency Phase Camps: A retrospective study', *The Lancet*, vol. 360, no. 9349, 2002, pp. 1927-1934.
- Stern, Nicholas, *The Economics of Climate Change: The Stern Review*, Cambridge University Press, Cambridge, United Kingdom, 2007.
- 'Survival, Change and Decision-Making in Rural Households: Three village case studies from Eastern Morocco', http://www.ifad.org/gender/thematic/morocco/mo_2.htm
- Sutherst, R. W., 'Global change and human vulnerability to vector-borne diseases', *Clinical Microbiology Reviews*, vol. 17, 2004, pp. 136-173.
- Swearingen, W. D., 'Drought hazard in Morocco', *Geographical Review*, vol. 82, no. 4, 1992, p. 401.
- Tarradell, M., 'Morocco Case Study: Analysis of national strategies for sustainable development', National Strategies for Sustainable Development: Challenges, approaches, and innovations based on a 19-country analysis', Working Paper (unedited), 2004.
- Tibbetts J., 'Driven to extremes health effects of climate change', *Environmental Health Perspectives*, vol. 115, no. 4, 2007, pp. A196-A203.
- Timaeus, I., K. Harris and F. Fairbairn, 'Can use of health care explain sex differentials in child mortality in the developing world?', United Nations (ed.), *Too young to die: Genes or gender?*, United Nations, New York, 1998.
- Ulijaszek S., 'Nutrition, infection, and child growth in Papua New Guinea', *Collegium Antropologicum*, vol. 24, no. 2, 2000, pp. 423-429.
- Van de Poel, E., O. O'Donnell and E. van Doorslaer, 'Are urban children really healthier? Evidence from 47 developing countries', *Social Science & Medicine*, vol. 65, no. 10, 2007, pp. 1986-2003.
- Van Lieshout, M. et al., 'Climate Change and Malaria: Analysis of the SRES climate and socio-economic scenario', *Global Environmental Change*, vol. 14, 2004, pp. 87-99.
- Victora, C. G., et al., 'Maternal and Child Undernutrition: Consequences for adult and human capital', *The Lancet*, vol. 371, 2008, pp. 340-357.
- Watson, R.T., M. C. Zinyowera and R. H. Moss (eds.), *The Regional Impacts of Climate Change: An assessment of vulnerability*, A Special Report of Intergovernmental Panel on Climate Change Working Group II, Cambridge University Press, United Kingdom, 1997.
- Woodruff, R. and T. McMichael, 'Climate Change and Human Health: All affected, but some more than others', *Social Alternatives*, vol. 23, no. 4, 2004, pp. 17-22.
- Ye, Y. et al., 'Effect of Meteorological Factors on Clinical Malaria Risk Among Children: An assessment using village-based meteorological stations and community-based parasitological survey', *BMC Public Health*, vol. 7, 2007, p. 101.
- Zhou, G. et al., 'Association between climate variability and malaria epidemics in the East African highlands', *Proceedings of the National Academy of Sciences*, vol. 101, 2004, pp. 2375-2380.
- ActionAid USA, 'Compensating for Climate Change: Principles and lessons for equitable adaptation funding', Discussion Paper, Washington D.C., 2007.
- ActionAid International, *Unjust Waters: Climate change, flooding and the protection of poor urban communities – Experiences from six African cities*, ActionAid International, London, November 2006.
- International Federation of Red Cross and Red Crescent Societies, *World Disasters Report 2006: Focus on neglected crises*, IFRC, Geneva, 2006.
- International Federation of Red Cross and Red Crescent Societies, *World Disasters Report 2007: Focus on discrimination*, IFRC, Geneva, 2007.
- International Panel on Climate Change, 'Impacts, Adaptation and Vulnerability', Fourth Assessment Report, Working Group II, IPCC, Geneva, 2007.
- International Panel on Climate Change, 'Synthesis Report', Fourth Assessment Report.
- Save the Children. *Legacy of Disasters: The impact of climate change on children*, Save the Children UK, London, 2007.
- _____, 'PV water purifiers to Thailand', *Refocus*, 2003, p. 20.
- _____, 'Millions of Children Could Be Saved With Better Nutrition', *Nutrition Today*, vol. 39, no. 4, July/August 2004, pp. 152-153.
- World Bank, *Climate Risk Management: Integrating adaptation into World Bank Group operations*, World Bank, Washington, D.C., 2006.

Internet-based resources

- Africa's Acute Vulnerability to Climate Change, http://unfccc.int/adaptation/adverse_effects_and_response_measures_art_48/items/3743.php
- Clean Up Greece, www.cleanupgreece.org.gr/site.asp?id=760
- Child Rights Information Network, 'The Berlin Commitment for Children of Europe and Central Asia', second draft, 1 April 2001, www.crin.org/docs/resources/publications/berlin2draft.pdf
- EcoClubs, www.ecoclubs.org/index_ing.html
- European Neighbourhood and Partnership Instrument, 'Morocco Strategy Paper 2007-2013', http://ec.europa.eu/world/enp/pdf/country/enpi_csp_morocco_en.pdf
- Global Movement for Children, www.gmfc.org
- Health and Environment Alliance, www.env-health.org/r/119
- Healthy Environments for Children Alliance, www.who.int/heca/en/
- Health and Environments Linkage Initiative, www.who.int/heli/en/
- Hyogo Framework for Action 2005-2015, www.unisdr.org/hfa
- International Federation of Red Cross and Red Crescent Societies, 'Early warning saves lives in Mozambique', www.ifrc.org/Docs/News/07/07060501/index.asp
- International Federation of Red Cross and Red Crescent Societies, 'Global Platform on Disaster Risk Reduction', www.ifrc.org/Docs/News/pr07/3007.asp
- International Federation of Red Cross and Red Crescent Societies, 'Riskland: Learning by playing', www.ifrc.org/docs/News/pr04/7104.asp
- International Federation of Red Cross and Red Crescent Societies, 'Sudan in Action', www.ifrc.org/what/disasters/dp/factsheet.asp

- International Federation of Red Cross and Red Crescent Societies, 'Youth – Ready to respond', www.redcross.int/EN/mag/magazine2007_1/24-25.html
- International Federation of Red Cross and Red Crescent Societies, 'Risk reduction conference must result in meaningful action "on the ground", says the International Federation', www.ifrc.org/Docs/News/pr07/3007.asp
- International Panel on Climate Change, Fourth Assessment Report, Working Group II, Impacts, Adaptation and Vulnerability, Policymakers Summary, www.ipcc.ch/pdf/assessment-report/ar4/syr/ar4_syr_spm.pdf
- International Symposium on Desertification and Migrations, Almería, Spain, 25-27 October 2006, www.sidym2006.com/imagenes/pdf/eng_conclusiones.pdf
- International Strategy for Disaster Reduction, Hyogo Framework for Action 2005-2015, www.unisdr.org/hfa
- Kavuncu Y. O. and S. D. Knabb, An Intergenerational Cost-Benefit Analysis of Climate Change, Department of Economics, University of California, Santa Barbara, 2001, <http://repositories.cdlib.org/cgi/viewcontent.cgi?article=1053&context=ucsbecon>
- North Atlantic Treaty Organization, Science Committee, Workshop on Water Scarcity, Land Degradation and Desertification in the Mediterranean Region – Environment and Security Linkages, Valencia, Spain, 10-11 December 2007, www.epa.gov/esd/land-sci/desert/images/exec3.pdf
- Schmuck, H., Empowering Women in Bangladesh, 2002, <http://www.reliefweb.int/rw/rwb.nsf/AllDocsByUNID/570056eb0ae62524c1256b6b00587224>
- Stern, Nicholas, The Economics of Climate Change: The Stern Review, Cambridge University Press, United Kingdom, 2007, www.hmtreasury.gov.uk/independent_reviews/stern_review_economics_climate_change/stern_review_report.cfm
- Office of the UN High Commissioner for Human Rights, Meeting of Experts on Human Rights and the Environment, 14-15 January 2002, www2.ohchr.org/english/issues/environment/viron/conclusions.htm
- Office of the UN High Commissioner for Human Rights, Convention on Access to Information, Public Participation and Access to Justice in Environmental Matters, Aarhus, Denmark, 25 June 1998, www2.ohchr.org/english/issues/environment/viron/bp1.htm
- Office of the UN High Commissioner for Human Rights, UN Convention on the Rights of the Child, New York, 20 November 1989, www2.ohchr.org/english/issues/environment/viron/bp1.htm
- Office of the UN High Commissioner for Human Rights, Committee on the Rights of the Child, www2.ohchr.org/english/issues/environment/viron/bp2.htm
- Office of the UN High Commissioner for Human Rights, South Africa, www2.ohchr.org/english/issues/environment/viron/bp4.htm#_ftn92
- Office of the UN High Commissioner for Human Rights, Bangladesh, www2.ohchr.org/english/issues/environment/viron/bp4.htm#_ftn92
- United Nations Environment Programme/United Nations Development Programme, Poverty Environment Facility, Mainstreaming Environment into National Development Planning, 2006, www.unpei.org/PDF/Guidance-Note-Mainstreaming.pdf
- UN Office for the Coordination of Humanitarian Affairs, IRIN Report: 'Bangladesh: Drowning leading cause of death among children', www.irinnews.org/Report.aspx?ReportId=74571
- United Nations Environment Programme climate change resources are at www.unep.org/themes/climatechange/
- United Nations Environment Programme, World Conservation Monitoring Centre, www.unep-cmc.org/climate/impacts.aspx, accessed 18 February 2008.
- United Nations Environment Programme, Finance Initiative, Innovative Financing for Sustainability, CEO Briefing, Adaptation and Vulnerability to Climate Change: The role of the finance sector, November 2006, www.unepfi.org/fileadmin/documents/CEO_briefing_adaptation_vulnerability_2006.pdf
- United Nations International Strategy for Disaster Reduction, Inter-Agency Task Force on Disaster Reduction, Thematic Cluster/Platform on Knowledge and Education, www.unisdr.org/eng/task%20force/working%20groups/knowledge-education/knowledge-education.htm
- United Nations Economic Commission for Europe, Aarhus Convention – Public Participation, www.unece.org/env/pp/acig.pdf
- United Nations Economic Commission for Europe, Draft elements for a long-term strategic plan for the Aarhus Convention, 6 March 2007, www.unece.org/env/pp/ltspl.htm
- United Nations Economic and Social Affairs, Population Division, <http://esa.un.org/unpp/p2k0data.asp>
- United Nations Environment Programme, Post Conflict Assessment Unit, <http://postconflict.unep.ch/index.php?prog=sudan>
- United Nations Children's Fund, UN General Assembly Special Session on Children, 'Review of the achievements in the implementation and results of the World Declaration on the Survival, Protection and Development of Children and Plan of Action for Implementing the World Declaration on the Survival, Protection and Development of Children in the 1990s', www.unicef.org/specialsession/documentation/documents/A-S27-13E.pdf
- United Nations Institute for Training and Research, National Adaptation Programme of Action, www.napa-pana.org
- United Nations Framework Convention on Climate Change, 'Annotated Guidelines for the Preparation of National Adaptation Programmes of Action', Decision 28/CP.7, July 2002, http://unfccc.int/files/cooperation_and_support/ldc/application/pdf/annguide.pdf
- United Nations Framework Convention on Climate Change, Climate Change: Impacts, vulnerabilities and adaptation in developing countries, V.1, Adaptation strategies, plans and programmes, 2007, http://unfccc.int/files/essential_background/background_publications_htmlpdf/application/txt/pub_07_impacts.pdf
- United Nations Framework Convention on Climate Change, Climate Change: Impacts, vulnerabilities and adaptation in developing countries, Table V-6, Impacts of climate change on the Millennium Development Goals, 2007, http://unfccc.int/files/essential_background/background_publications_htmlpdf/application/txt/pub_07_impacts.pdf
- United States Environmental Protection Agency, Children's Environmental Health: Report 2006, <http://yosemite.epa.gov/ochp/ochpweb.nsf/content/chm.htm>
- US Centers for Disease Control and Prevention, www.cdc.gov/malaria
- World Youth Report 2007, 'Young People's Transition to Adulthood: Progress and challenge', www.un.org/esa/socdev/unyin/documents/wyr07_complete.pdf
- World Health Organization on children's environmental health, <http://www.who.int/ceh/en/>
- World Health Organization, Report on a Workshop on a strategy of youth participation in the environment and health process, Dublin, 27-28 September 2005, www.euro.who.int/document/EEHC/20mtg_Helsinki_YouthStrategy.pdf
- World Health Organization, Climate Change and Human Health: Risks and responses, www.who.int/globalchange/climate/en/ccSCREEN.pdf, accessed on 26 November 2004.

WHO, Children and Malaria,
www.rbm.who.int/cmc_upload/0/000/015/367/RBMInfosheet_6.htm,
accessed on 17 February 2008.

World Meteorological Organization climate change resources at
the Intergovernmental Panel on Climate Change, www.ipcc.ch

World Bank/African Development Bank Group/Asian Development
Bank/Department for International Development and partners,
*Poverty and Climate Change: Reducing the vulnerability of the
poor through adaptation*, World Bank/AfDB/ADB/DFID, 2003,
[http://ec.europa.eu/development/icenter/repository/env_cc_varg_
poverty_and_climate_change_en.pdf](http://ec.europa.eu/development/icenter/repository/env_cc_varg_poverty_and_climate_change_en.pdf)

World Climate Programme, www.wmo.ch/web/wcp/wcp-home.html

World Climate Research Programme, www.wmo.ch/web/wcrp/

World Population Foundation, 'Reproductive Rights',
www.wpf.org/reproductive_rights_article/

Design and layout: Bernard & Co., Siena, Italy
Printing: Industria Grafica Pistolesi, Siena, Italy
November 2008

For every child
Health, Education, Equality, Protection
ADVANCE HUMANITY



UNICEF Innocenti Research Centre
Piazza SS. Annunziata, 12
50122 Florence, Italy
Tel: (+39) 055 20 330
Fax: (+39) 055 2033 220
florence@unicef.org
www.unicef-irc.org

ISBN: 978-89129-83-8

© The United Nations Children's Fund (UNICEF)
November 2008